

V217 (L) / V218 (T) Series 3 Way L/T Port Full Bore Ball Valves

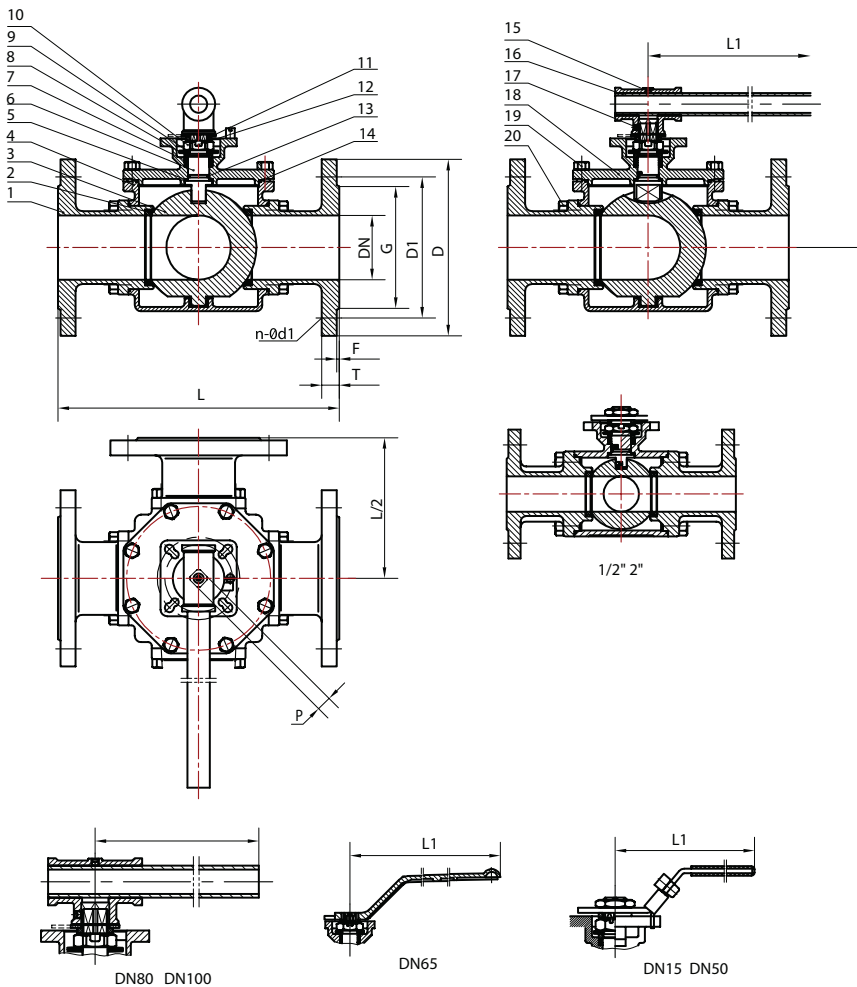

Material List

No	Part Name	Material
1	Cap	AISI316
2	Seat	R-PTFE
3	Ball	AISI316
4	Body	AISI316
5	Gasket	PTFE
6	Stem	AISI316
7	Packing	PTFE
8	Packing Gland	AISI304
9	Disc Spring	AISI304
10	Stem Nut	AISI304
11	Thrust Washer	AISI201
12	O-Ring	Viton
13	Cap Gasket	PTFE
14	Screw Nail	ASTM A193-B8
15	Handle	AISI304
16	Screw Nail	ASTM A193-B8
17	Cap	AISI316
18	Hex Bolts	ASTM A193-B8
19	Hex Bolts	ASTM A193-B9
20	Hex Bolts	ASTM A193-B10

L / T Port Flow Plan Options

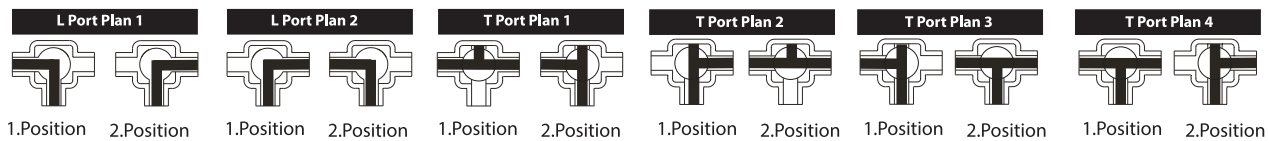

Dimensions(mm)

DN	D	PN16		PN40		#150		G	T	F	L	H	L1	P	ISO 5211	Torque Values (Nm)	Weight (Kg)
		D1	n-Ød1	D1	n-Ød1	D1	n-Ød1										
15	95	65	4-14	65	4-14	60,3	44-15,75	45	16	2	152	70	120	9	F03 / 04	9	3,4
20	105	75	4-14	75	4-14	69,8	44-15,75	58	18	2	167	82	160	11	F04 / 05	14	4,8
25	115	85	4-14	85	4-14	79,4	44-15,75	68	18	2	190	86	160	11	F04 / 05	16	5,9
32	140	100	4-18	100	4-18	88,9	44-15,75	78	18	2	208	104	185	14	F05 / 07	26	10,6
40	150	110	4-18	110	4-18	98,4	44-15,75	88	18	3	220	110	185	14	F05 / 07	32	12,6
50	165	125	4-18	125	4-18	120,6	44-19,05	102	20	3	254	133	250	17	F07 / 10	60	19,5
65	185	145	4-18	145	4-18	139,7	44-19,05	122	22	3	292	200	500	22	F10 / 12	92	28,2
80	200	160	8-18	160	8-18	152,4	44-19,05	138	24	3	305	216	500	22	F10 / 12	121	39,6
100	235	180	8-18	190	8-22	190,5	8-19,05	162	24	3	369	230	650	22	F10 / 12	180	63,8