



## Mass flow controller (MFC) / Mass flow meter (MFM) for gases

- Nominal flow ranges from 20 l<sub>N</sub>/min up to 2500 l<sub>N</sub>/min
- High measuring accuracy and repeatability with very fast response times
- Long-term stability of the flow calibration
- Simpler device exchange due to configuration memory
- Optional: ATEX II Cat. 3G/D or USP Class VI, FDA, EC 1935 conformity

Product variants described in the data sheet may differ from the product presentation and description.

### Can be combined with

	<b>Type 6013</b> Plunger valve 2/2 way direct-acting	▶
	<b>Type 6027</b> Direct-acting 2/2 way plunger valve	▶
	<b>Type 0330</b> Direct-acting 2/2 or 3/2-way pivoted armature valve	▶
	<b>Type 0290</b> Servo-assisted 2/2-way diaphragm valve	▶
	<b>Type ME43</b> Fieldbus gateway	▶
	<b>Type ME63</b> Industrial Ethernet gateway, IP65/ IP67/ IP69k	▶

### Type description

The mass flow controller (MFC) / mass flow meter (MFM) Type 8746 for gases is suitable for a wide range of applications, e.g. metal and glass manufacturing or processing, fermentation processes, test benches or filling systems and packaging machines. Type 8746 is available in two variants: A variant with several analogue or digital (communication) interfaces and a variant with a pure CANopen-based interface. The latter is suitable for integration in existing CANopen networks or - in combination with a Bürkert fieldbus gateway - for integration in all common industry standards for Industrial Ethernet or fieldbus. This variant is tailor-made for applications with many control loops. Up to 32 MFCs / MFMs can be connected to one fieldbus gateway. The gateway transmits the internal CANopen-based communication to Industrial Ethernet and fieldbus standards. The mass flow controller / mass flow meter can always be switched between bus and CANopen communication. Type 8746 can be configured as an MFM or an MFC according to demand. Optionally, up to four calibration curves can be stored in the device. The thermal inline sensor is located directly in the main flow and achieves fast response times and a high level of measuring accuracy with long-term stable calibration. As the actuator, a Bürkert direct-acting, electromagnetic proportional valve or motor valve guarantees high response sensitivity. The integrated PI controller ensures excellent control characteristics of the MFC. Type 8746 is characterised by low pressure drop, even at high flow rates, and is especially designed for use in harsh environments thanks to its high IP protection class and explosion protection.

## Table of contents

<b>1. General Technical Data</b>	<b>4</b>
1.1. General.....	4
1.2. Version with electromagnetic proportional valve.....	4
1.3. Version with electromotive proportional valve.....	5
<b>2. Approvals</b>	<b>6</b>
<b>3. Materials</b>	<b>6</b>
3.1. Chemical Resistance Chart – Bürkert resistApp.....	6
<b>4. Dimensions</b>	<b>6</b>
4.1. Devices with bus/CANopen interface .....	7
MFC with valve Type 2873 (9 W coil).....	7
MFC with valve Type 2875 (16 W coil).....	7
MFC with valve Type 2836 (24 W coil).....	8
MFC with valve Type 3280.....	9
MFC with valve Type 3285.....	10
MFM.....	11
4.2. Devices with analog or PROFIBUS-DP interface .....	12
MFC with valve Type 2873 (9 W coil).....	12
MFC with valve Type 2875 (16 W coil).....	12
MFC with valve Type 2836 (24 W coil).....	13
MFC with valve Type 3280.....	14
MFC with valve Type 3285.....	15
MFM.....	16
<b>5. Device/Process connections</b>	<b>17</b>
5.1. CANopen or CANopen-based bus.....	17
5.2. Analogue.....	17
5.3. PROFIBUS-DP.....	17
<b>6. Performance specifications</b>	<b>18</b>
6.1. Pressure Loss Diagram of the MFM .....	18
6.2. Flow characteristic.....	18
Nominal flow range of typical gases.....	18
6.3. Derating diagram .....	18
Electromotive versions.....	18
<b>7. Product operation</b>	<b>19</b>
7.1. Measuring principle .....	19
<b>8. Product design and assembly</b>	<b>19</b>
8.1. Product features .....	19
Measures to comply with ATEX requirements .....	19
<b>9. Product accessories</b>	<b>20</b>
9.1. Bürkert Communicator Software.....	20
<b>10. Ordering information</b>	<b>20</b>
10.1. Bürkert eShop – Easy ordering and quick delivery.....	20

10.2. Recommendation regarding product selection .....21  
10.3. Bürkert product filter.....21  
10.4. Ordering chart accessories.....21

## 1. General Technical Data

### 1.1. General

Product properties	
<b>Materials</b>	
Body	Stainless steel or aluminium
Housing	Aluminium die casting (coated)
Seal	FKM or EPDM (depending on gas) <sup>1.)</sup>
Configuration memory (included in delivery)	EEPROM (µSIM card: stores all parameters (e.g. individual fieldbus or controller settings) relevant for device replacement without software tool)
<b>Electrical data</b>	
Operating voltage	24 V DC
Voltage tolerance	± 10 %
Residual ripple	± 2 %
Electrical connection	M12 plug, 5 pin For analog and PROFIBUS-DP version additionally: M12 socket, 5 pin
<b>Medium data</b>	
Operating medium	Neutral, non-contaminated gases, others on request
Calibration medium	Operating gas or air with correction function
Medium temperature	- 10 °C <sup>2.)</sup> ...+ 70 °C (- 10 °C <sup>2.)</sup> ...+ 60 °C with oxygen)
<b>Process/Port connection &amp; communication</b>	
Port connection	G or NPT ¼", ⅜", ½", ¾", 1" Flange
Digital (communication) interfaces	CANopen, CAN based bÜS or PROFIBUS-DP
Analogue interfaces	4...20 mA, 0...20 mA, 0...10 V or 0...5 V Input impedance > 20 kΩ (voltage) o.R. < 300 Ω (current) Max. Current: 10 mA (voltage output); max. Load: 600 Ω (current output)
<b>Environment and installation</b>	
Installation position	Horizontal or vertical
Ambient temperature	- 10 °C...+ 50 °C <sup>3.)</sup> (higher temperatures on request)
<b>Accessories</b>	
Software-Tool	Bürkert Communicator Detailed information can be found in chapter "9.1. Bürkert Communicator Software" on page 20.

1.) When using the motor valve additionally:

- Type 3280 DN 4: valve seat seal from PEEK

- Type 3285: valve seat seal from Al2O3

2.) When using the motor valve, the minimum medium temperature is 0 °C

3.) Max. Ambient temperature for versions with cULus approval is 40 °C

### 1.2. Version with electromagnetic proportional valve

Type 8746 can be configured as MFC or MFM as required. The MFC version uses direct-acting proportional valves of the 287x series. These electromagnetic proportional valves are normally closed and stand for highest measuring accuracy and repeatability with response times of a few hundred milliseconds.

Product properties	
Dimensions	Detailed information can be found in chapter "4. Dimensions" on page 6.
Total weight	approx. 1.8 kg (AI, 16 W valve) approx. 3.1 kg (VA, 16 W valve)
<b>Proportional valve (electromagnetic)</b>	
Nominal valve sizes	0.8...12 mm
k <sub>VS</sub> value range	0.02...2.5 m³/h
LED display	RGB-LED acc. to NAMUR NE107

Performance data	
Nominal flow range ( $Q_{Nom}$ )	20...1500 $l_N/min$ ( $N_2$ ) MFM up to 2500 $l_N/min$ ( $N_2$ )
Measuring range	1:50 <sup>1.)</sup>
Max. Operating pressure (Overpressure to atmospheric pressure)	10 bar, for MFCs the max. pressure depends on the media and the orifice of the valve, optional up to 25 bar for MFM
Measuring accuracy	$\pm 1.5\%$ o.R. $\pm 0.3\%$ F.S. (after 15 min warm up time)
Repeatability	$\pm 0.1\%$ F.S.
Settling (MFC)/response (MFM) time ( $t_{95\%}$ )	< 500 ms
Electrical data	
Power consumption <sup>2.)</sup>	Max. 2 W (as MFM) Max. 10.5...29.5 W (as MFC, depending on the proportional valve type)
Environment and installation	
Degree of protection	IP65

1.) In vertical installation position with flow from top to bottom the measuring range is 1:10.

2.) Data refers to the typical power consumption (at 23 °C ambient temperature, nominal flow rate and 30 min control mode). The specifications according to UL 61010-1 can differ (see Operating Manual).

### 1.3. Version with electromotive proportional valve

Type 8746 with electromotive proportional valve is especially suitable for applications with high inlet pressures up to 22 bar or high flow rates (with low pressure loss). Thanks to their very low holding capacity, these valves can drastically reduce the less energy consumption of a system. When de-energized, the motor valves remain in position. The maximum duty cycle of the motor depends on the ambient temperature. The duty cycle is not the duty cycle of the appliance but the duty cycle of the motor. This is only switched on when the valve is to move. The duty cycle of the motor increases drastically due to frequent changes in the setpoint value. More detailed information about the derating curve can be found in the chapter "6.3. Derating diagram" on page 18.

Product properties	
Dimensions	Detailed information can be found in chapter "4. Dimensions" on page 6.
Total weight	Ca. 1.67 kg (AI, Standard, valve Type 3280) Ca. 2.94 kg (VA, Standard, valve Type 3280)
LED display <sup>1.)</sup>	On MFM: RGB-LED acc. to NAMUR NE107 On valve: RGB-LED to indicate valve opening
Proportional valve (electromotive)	
Nominal valve sizes	2...20 mm
$k_{VS}$ value	0.5...7.8 $m^3/h$
Performance data	
Nominal flow range ( $Q_{Nom}$ )	20...2500 $l_N/min$ ( $N_2$ )
Measuring range	1:50 <sup>2.)</sup>
Max. Operating pressure (Overpressure to atmospheric pressure)	22 bar (for MFC the max. operating pressure depends on the nominal valve size)
Measuring accuracy	$\pm 2\%$ o.R. $\pm 0.5\%$ F.S. (after 15 min warm up time)
Repeatability	$\pm 0.5\%$ F.S.
Settling (MFC)/response (MFM) time ( $t_{95\%}$ )	< 5 s
Electrical data	
Power consumption	Max. 2 W (as MFM) Max. 10.5 W (as MFC) <sup>3.)</sup>
Environment and installation	
Degree of protection	IP54 (with valve Type 3280) or IP50 (with valve Type 3285)

1.) Detailed description of the LED colours: see Operating Manual.





2.) In vertical installation position with flow from top to bottom the measuring range is 1:10.

3.) Data during the movement of the engine valve. The holding power of the valve is < 1 W.

## 2. Approvals

### Note:

- The approvals and conformities listed below must be stated when making enquiries. This is the only way to ensure that the product complies with all required specifications.
- Not all available types can be supplied with the approvals or conformities below.

Approvals	Description
	UL Listed according to DIN EN 61010-1 for USA and Canada
	<b>Conformity of all materials in contact with the medium</b> USP Class VI chapter "87 in vitro" and „88 in vivo, Implantation“
FDA	<b>Conformity of all materials in contact with the medium</b> FDA – Code of Federal Regulations Title 21 Paragraph 177 (CFR 21 177.2600)
	<b>Conformity of all materials in contact with the medium</b> Regulation (EC) No. 1935/2004 on materials and objects intended to come into contact with food
	<b>ATEX</b> ATEX/ IECEx: II 3G Ex nA IIC T* Gc X and II 3D Ex tc IIIC T***°C Dc X acc. to DIN EN 60079-0 and DIN EN 60079-15, T3/4 and T160 °C/135 °C depending on device variant

## 3. Materials

### 3.1. Chemical Resistance Chart – Bürkert resistApp

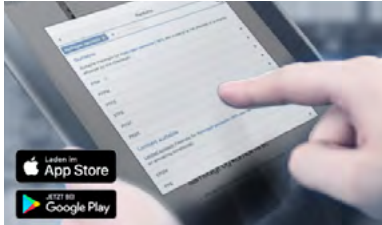

**Bürkert resistApp – Chemical Resistance Chart**

You want to ensure the reliability and durability of the materials in your individual application case? Verify your combination of media and materials on our website or in our resistApp.

[Start Chemical Resistance Check](#)

## 4. Dimensions

### Note:

The following table applies to the following dimensions.

A	Thread depth [mm]
G ¼	12
NPT ¼	11
G ⅜	12
NPT ⅜	11
G ½	15
NPT ½	14
G ¾	16
NPT ¾	15

4.1. Devices with bÜS/CANopen interface

MFC with valve Type 2873 (9 W coil)

Note:

Dimensions in mm

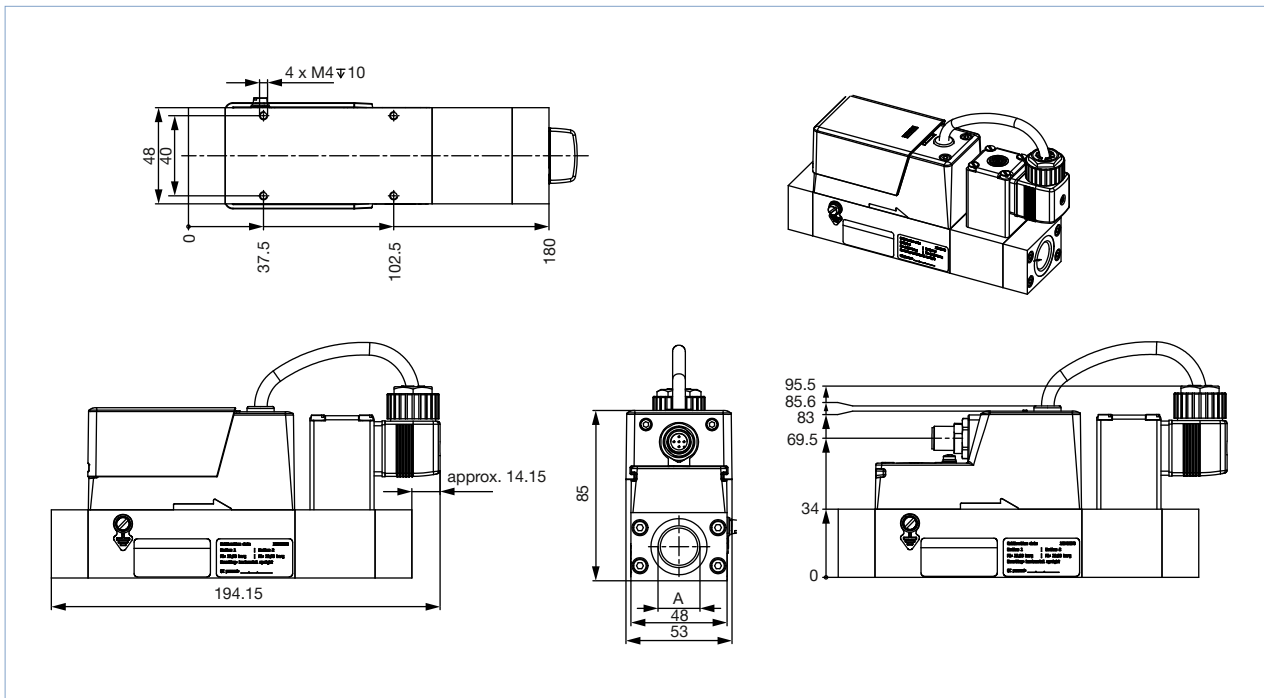

MFC with valve Type 2875 (16 W coil)

Note:

Dimensions in mm

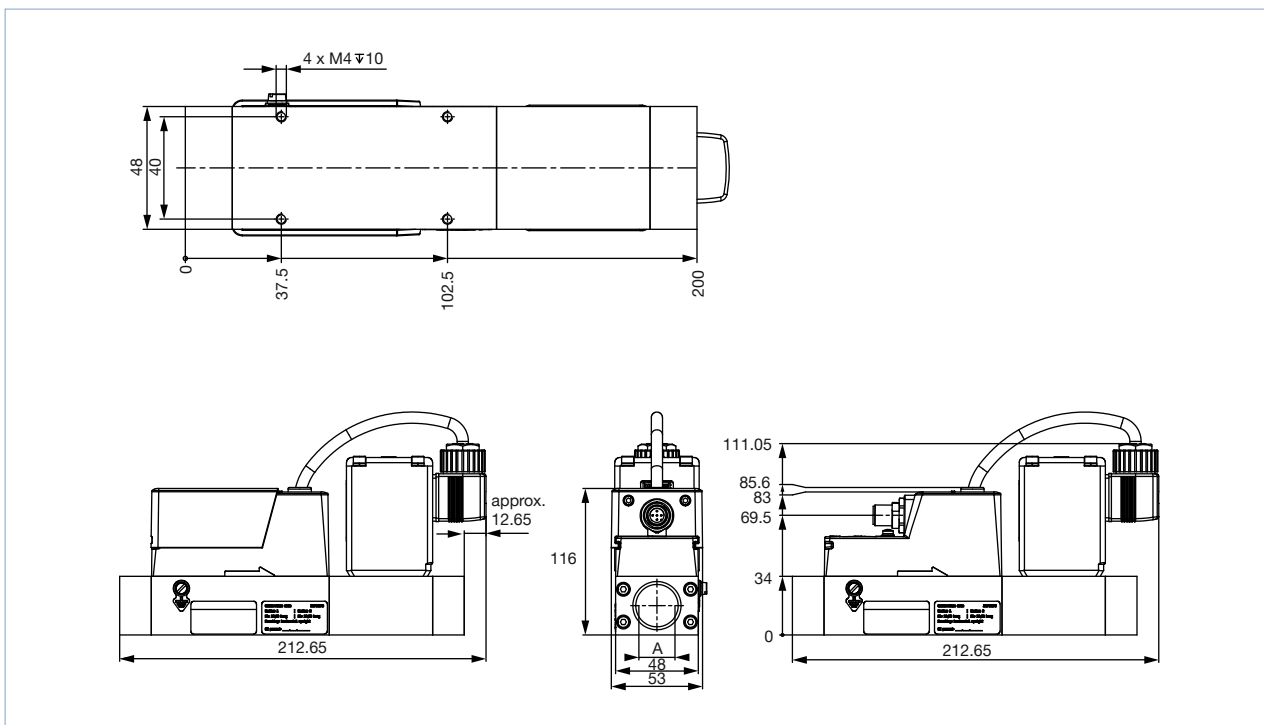

**MFC with valve Type 2836 (24 W coil)**

**Note:**

- From a nominal flow rate  $Q_{Nom} > 1500 \text{ l}_N/\text{min}$  the overall length increases by 30 mm.
- Dimensions in mm

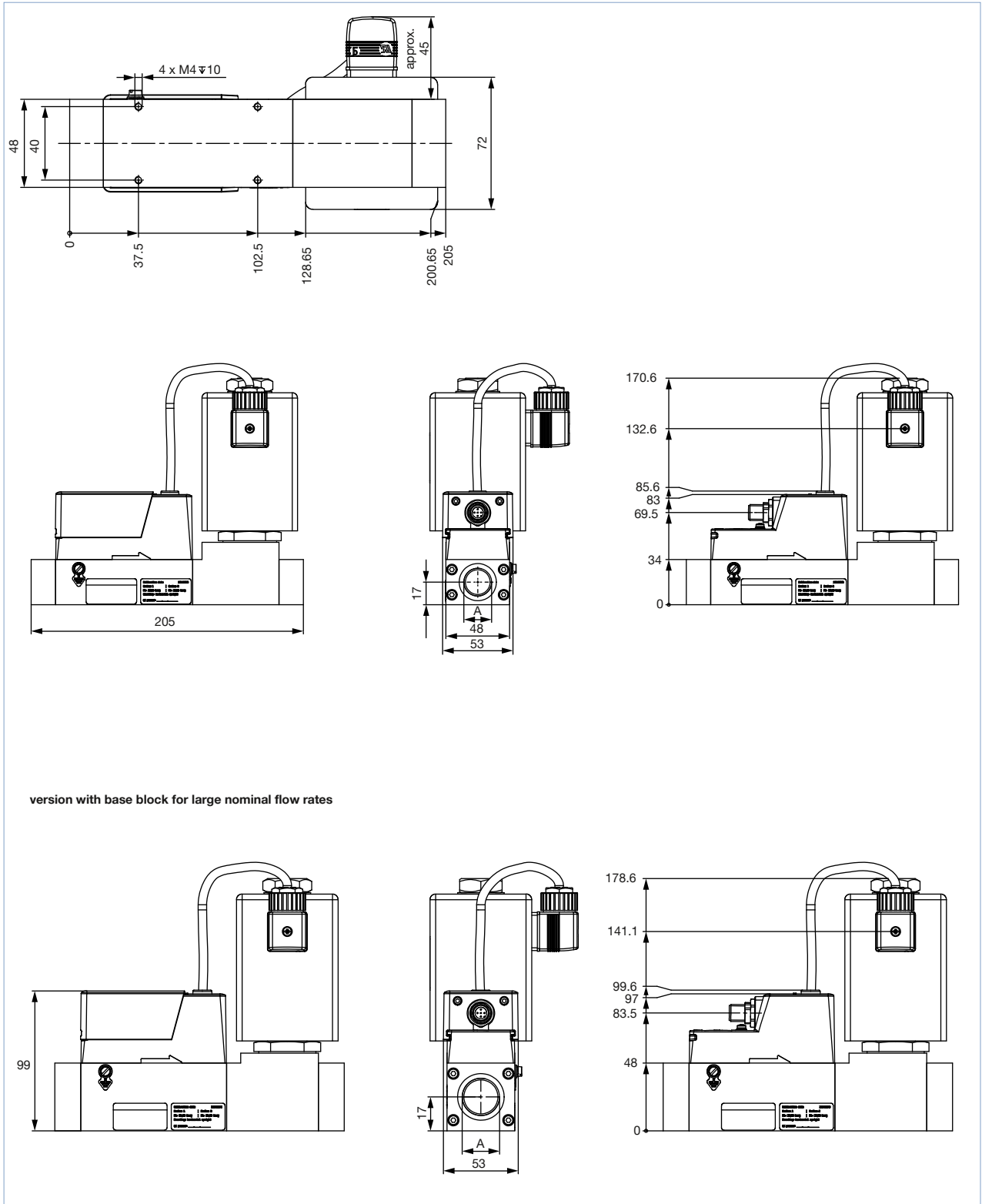

DTS 1000241027 EN Version: Q Status: RL (released | freigegeben | valide) printed: 06.08.2021



**MFC with valve Type 3280**

**Note:**

- From a nominal flow rate  $Q_{Nom} > 1500 \text{ l}_N/\text{min}$  the overall length increases by 30 mm.
- Dimensions in mm

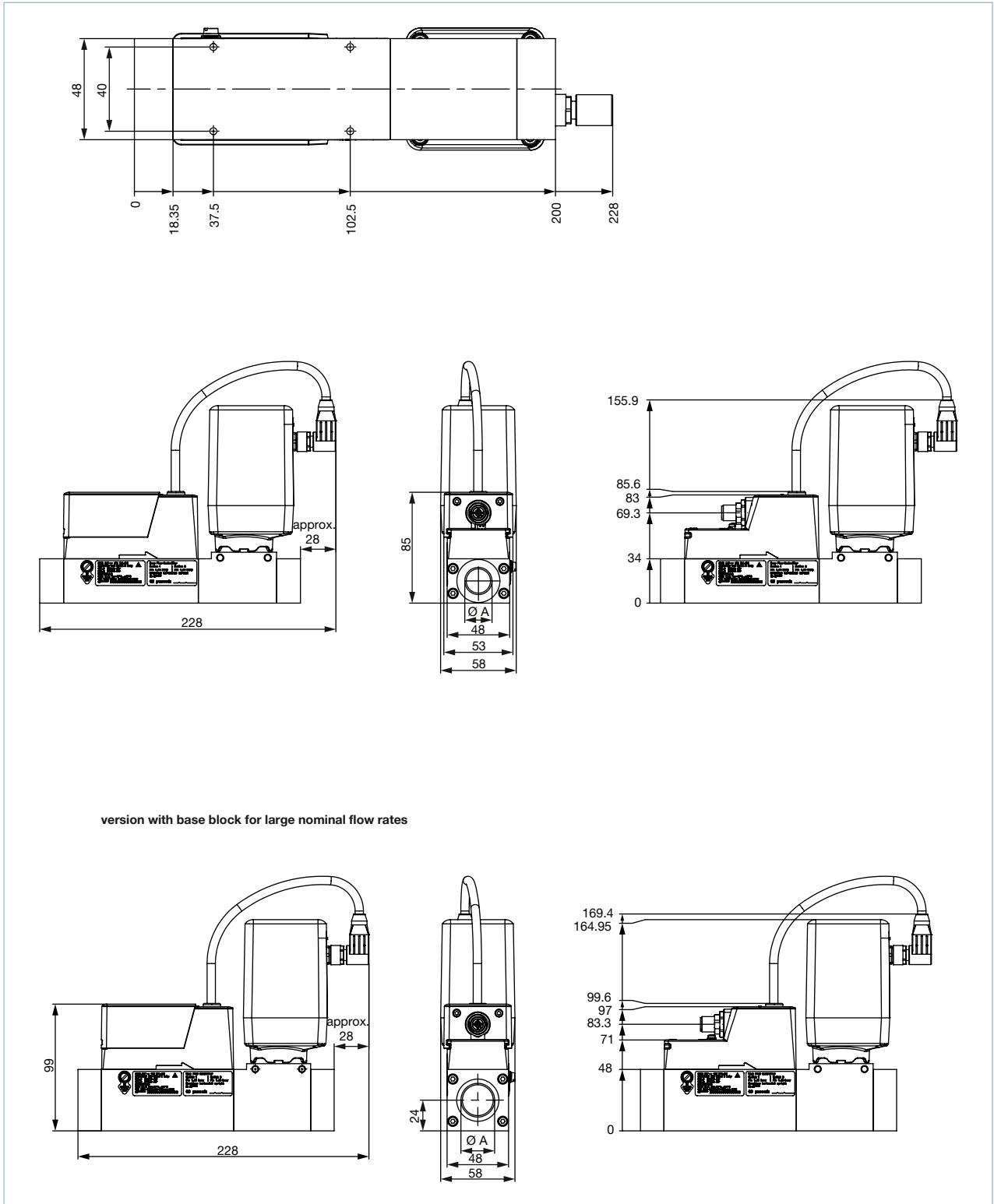

DTS 1000241027 EN Version: Q Status: RL (released | freigegeben | valide) printed: 06.08.2021

MFC with valve Type 3285

Note:

- From a nominal flow rate  $Q_{Nom} > 1500 \text{ l}_N/\text{min}$  the overall length increases by 30 mm.
- Dimensions in mm

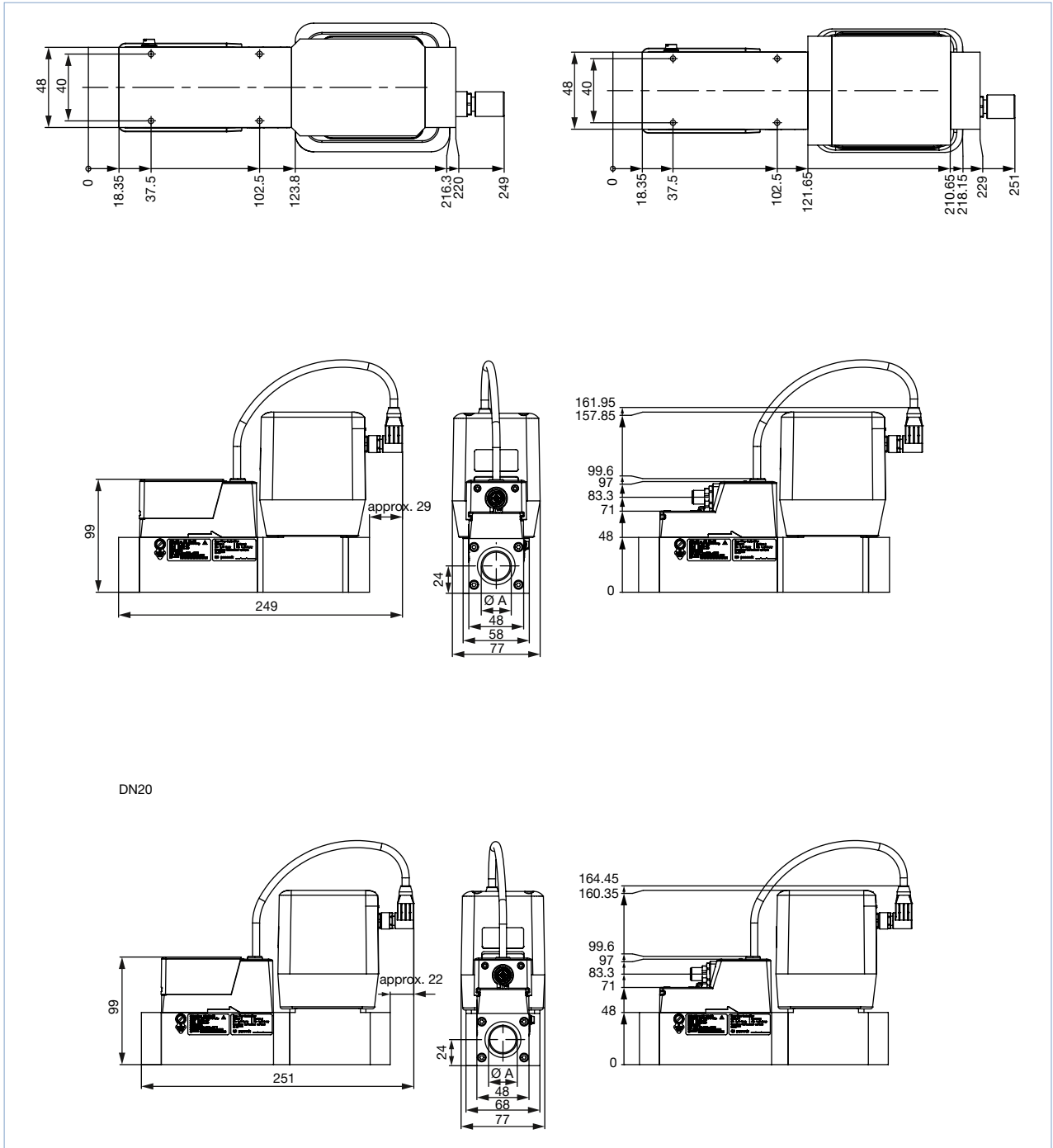

**MFM**

**Note:**

- From a nominal flow rate  $Q_{Nom} > 1500 \text{ l}_N/\text{min}$  the overall length increases by 30 mm.
- Dimensions in mm

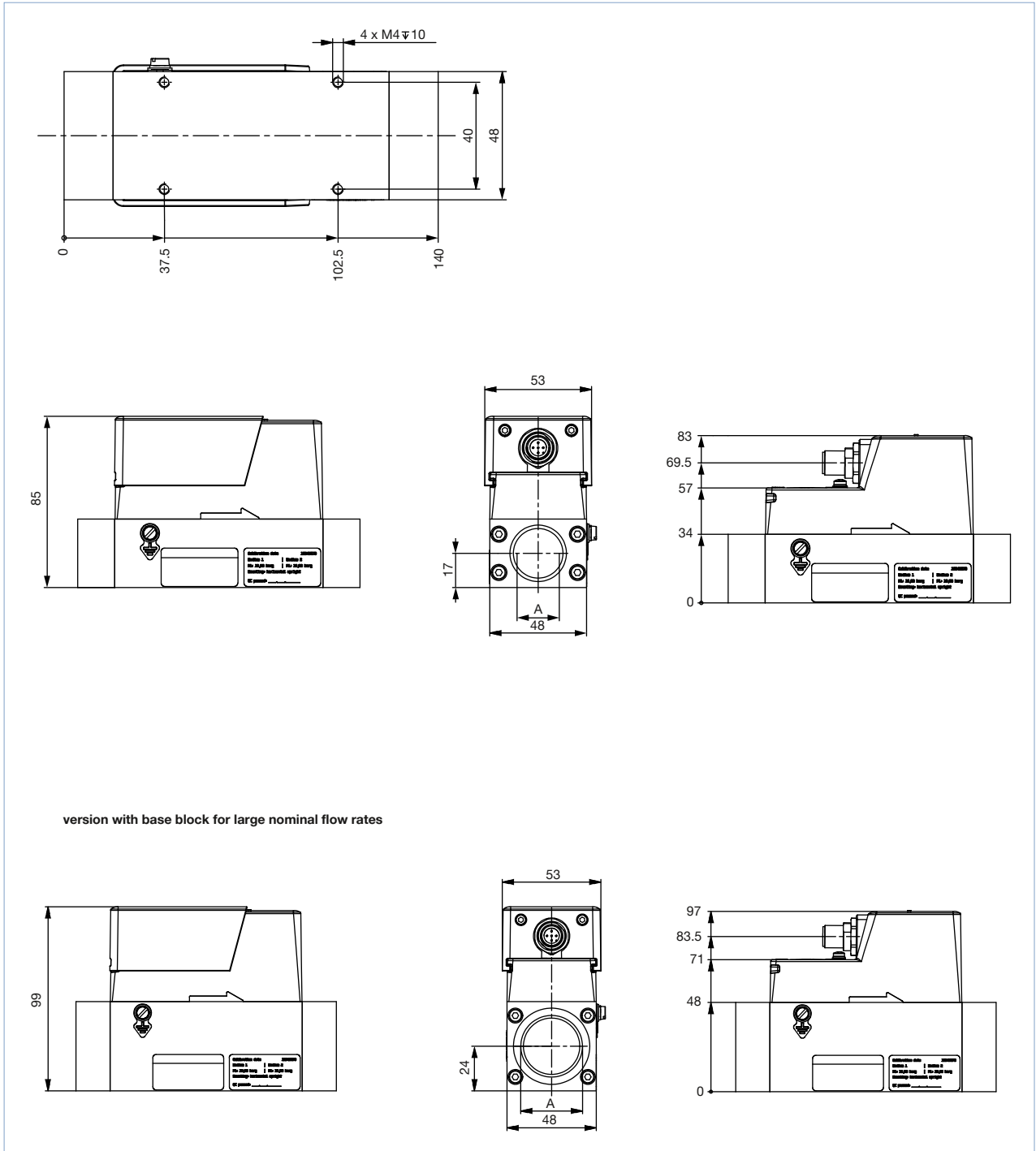

4.2. Devices with analog or PROFIBUS-DP interface

MFC with valve Type 2873 (9 W coil)

Note:

Dimensions in mm

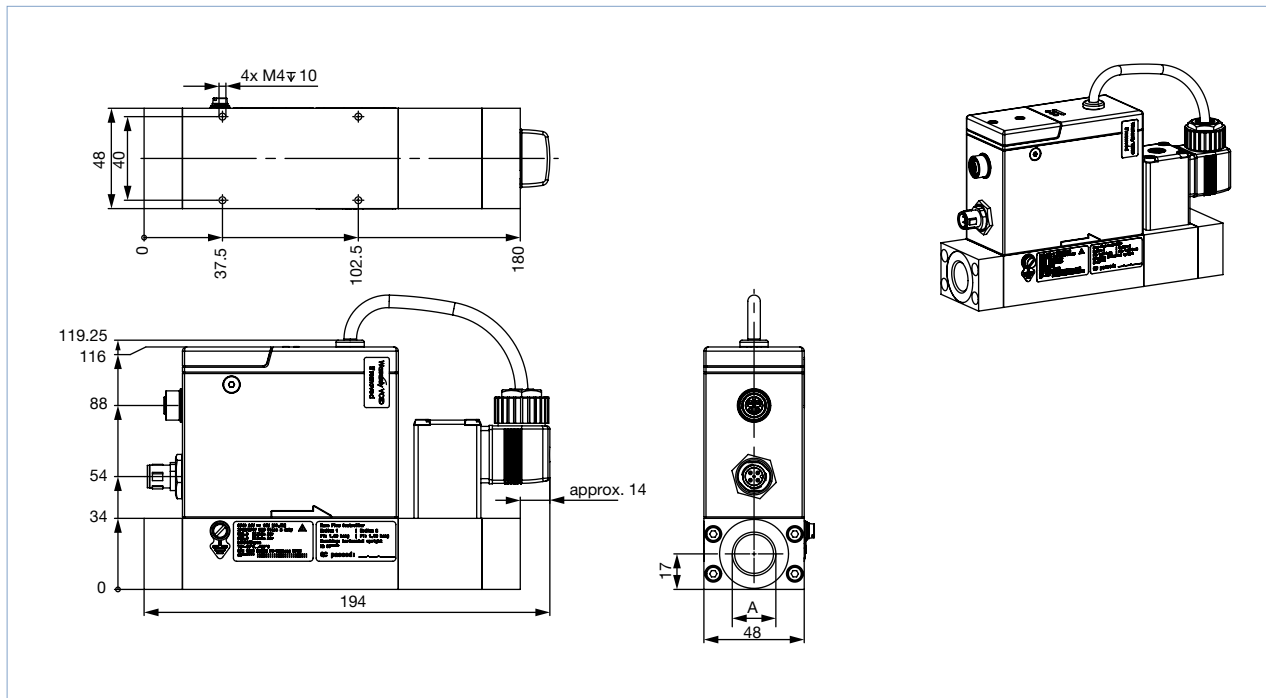

MFC with valve Type 2875 (16 W coil)

Note:

Dimensions in mm

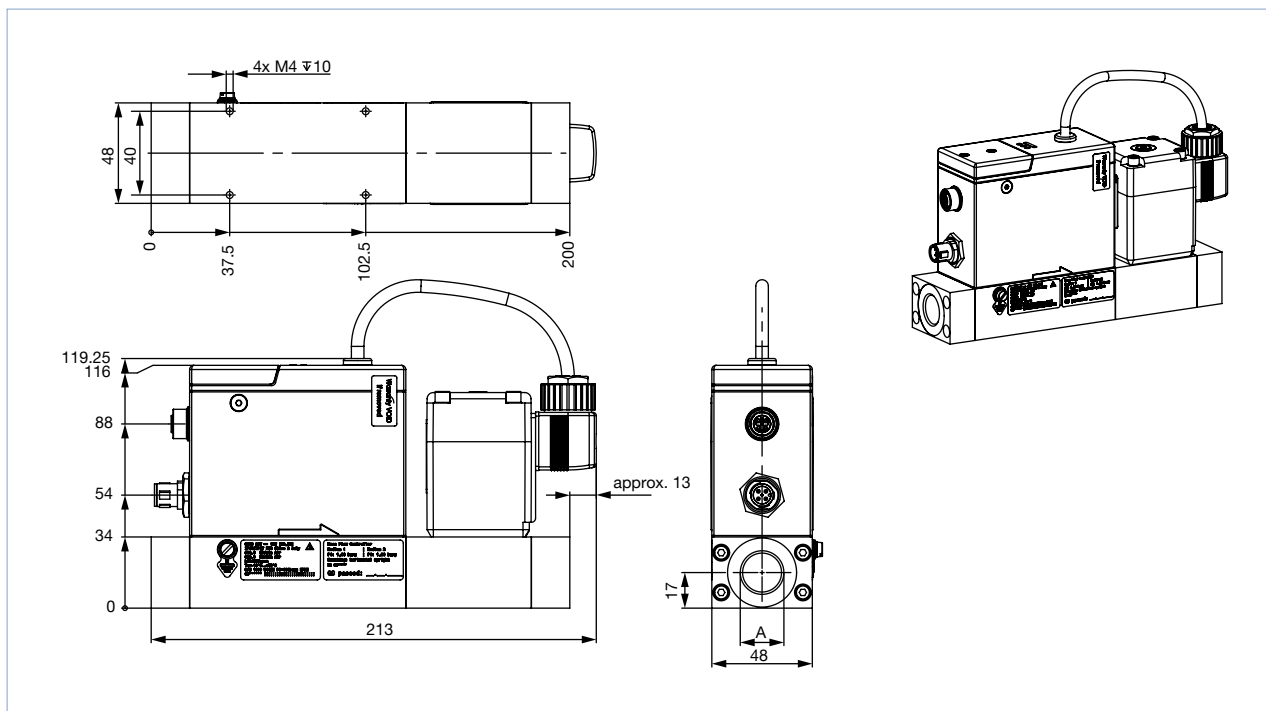

**MFC with valve Type 2836 (24 W coil)**

**Note:**

- From a nominal flow rate  $Q_{Nom} > 1500 \text{ l}_N/\text{min}$  the overall length increases by 30 mm.
- Dimensions in mm

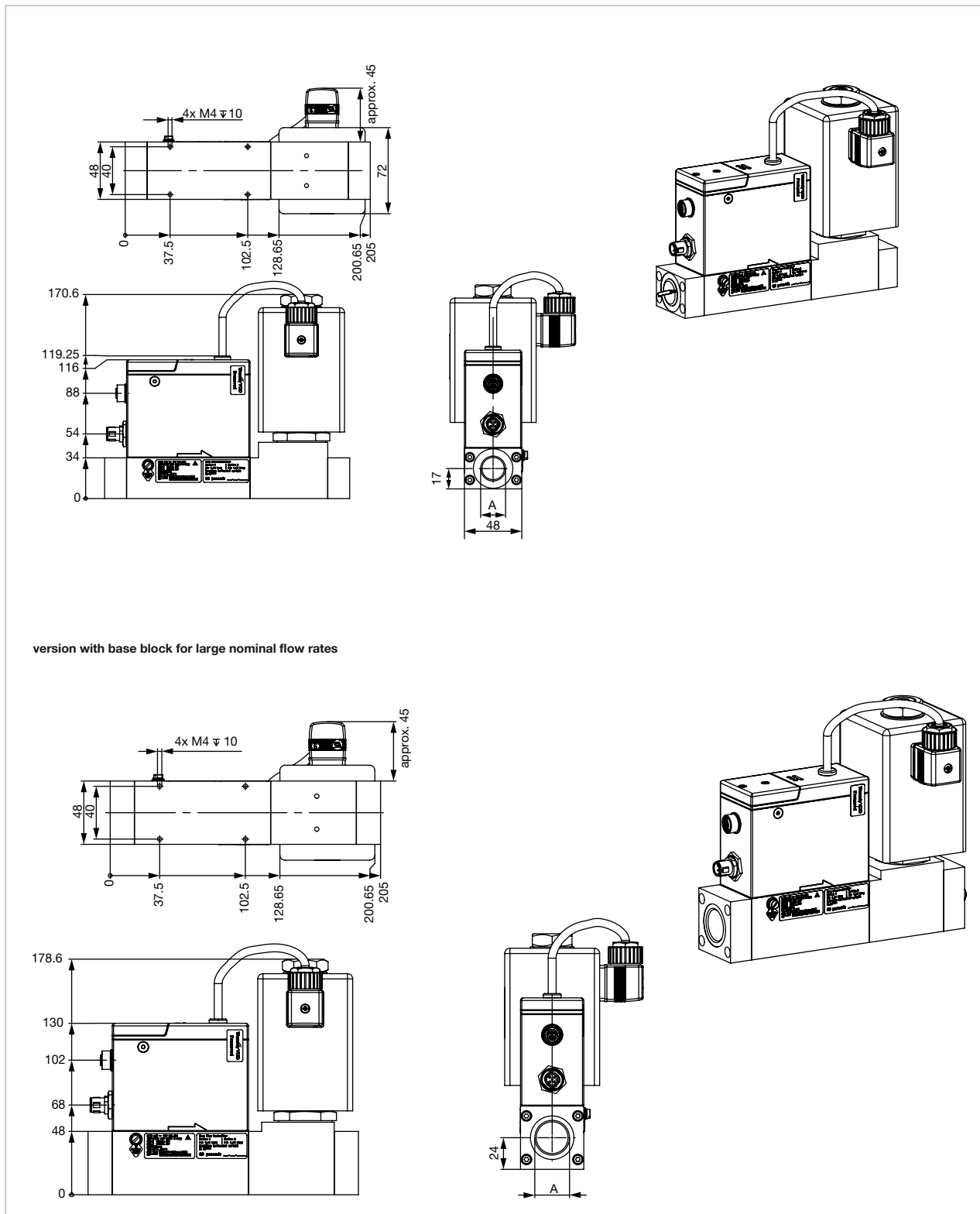

DTS 1000241027 EN Version: Q Status: RL (released | freigegeben | valide) printed: 06.08.2021

MFC with valve Type 3280

Note:

- From a nominal flow rate  $Q_{Nom} > 1500 \text{ l}_N/\text{min}$  the overall length increases by 30 mm.
- Dimensions in mm

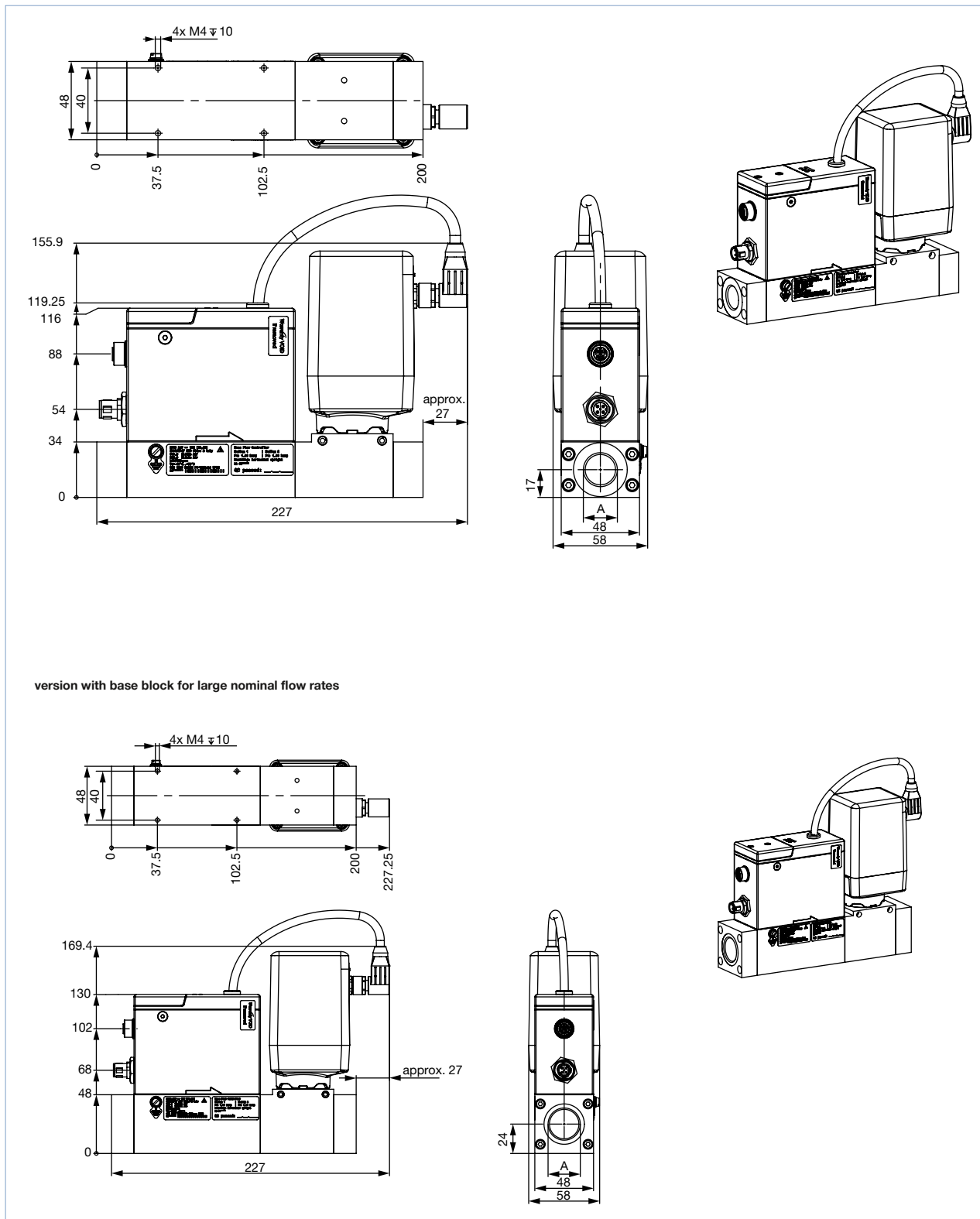

DTS 1000241027 EN Version: Q Status: RL (released | freigegeben | valide) printed: 06.08.2021

MFC with valve Type 3285

Note:

- From a nominal flow rate  $Q_{Nom} > 1500 \text{ l}_N/\text{min}$  the overall length increases by 30 mm.
- Dimensions in mm

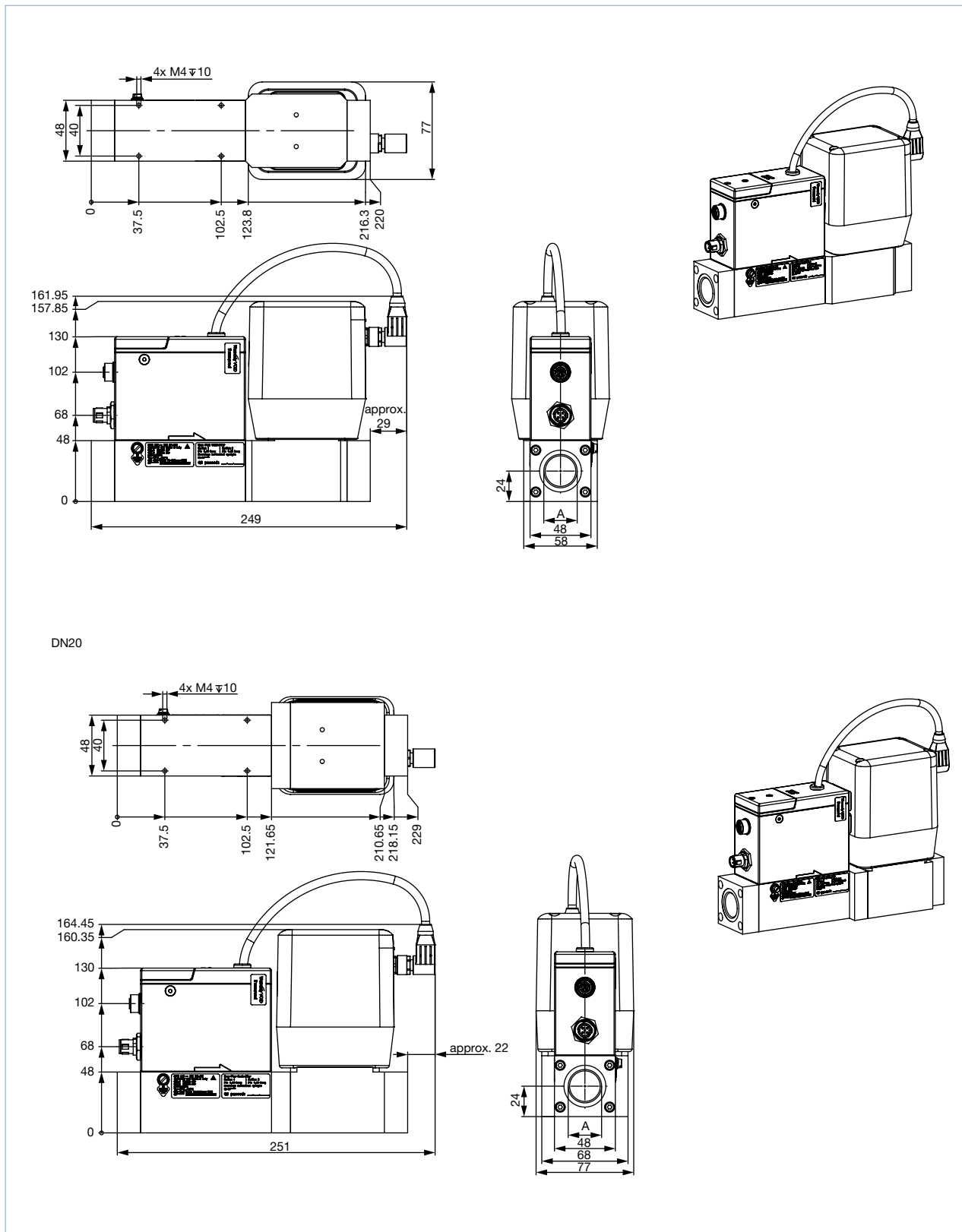

DTS 1000241027 EN Version: Q Status: RL (released | freigegeben | valide) printed: 06.08.2021

**MFM**

**Note:**

- From a nominal flow rate  $Q_{Nom} > 1500 \text{ l}_N/\text{min}$  the overall length increases by 30 mm.
- Dimensions in mm

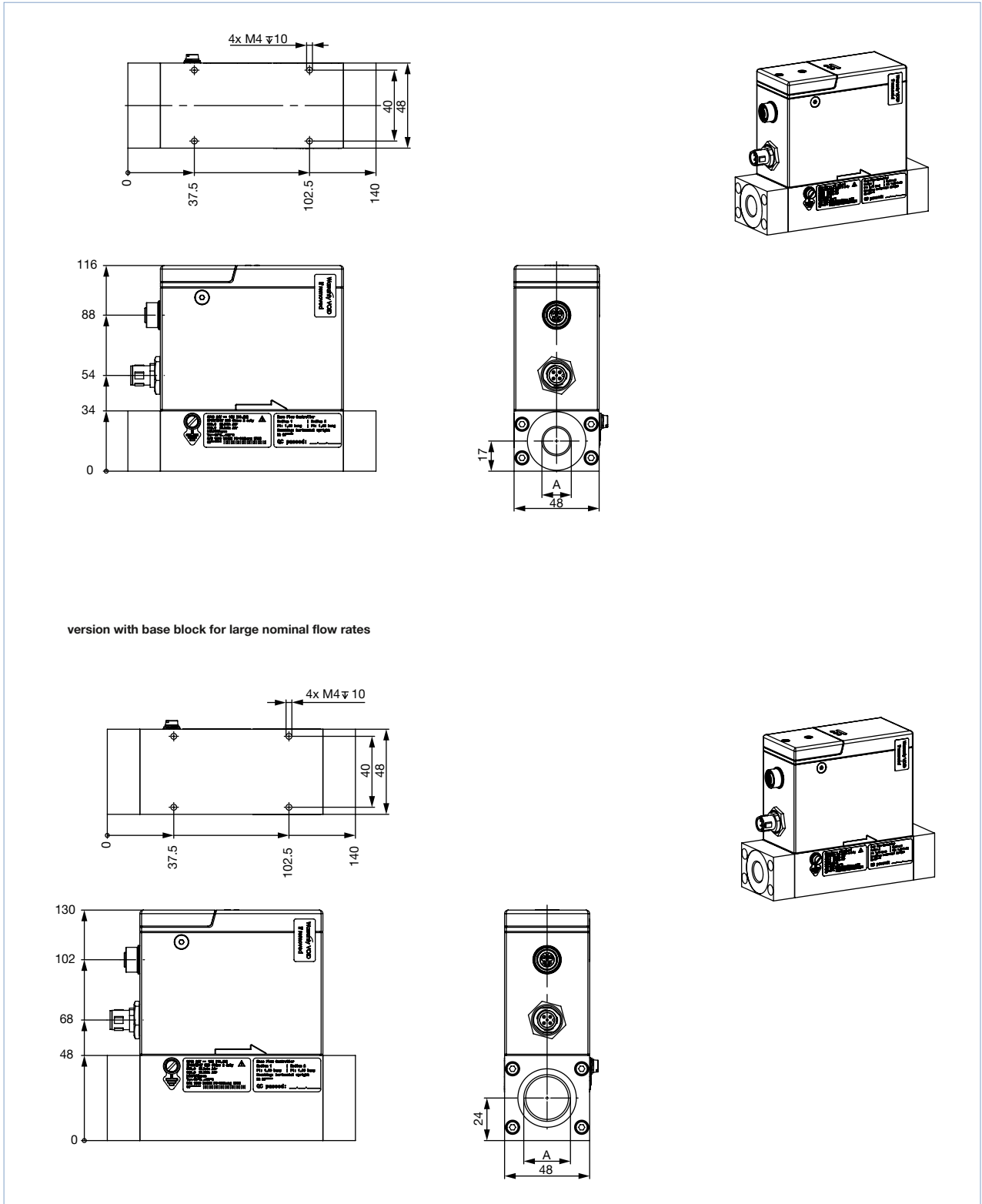

DTS 1000241027 EN Version: Q Status: RL (released | freigegeben | valide) printed: 06.08.2021



## 5. Device/Process connections

### 5.1. CANopen or CANopen-based büS

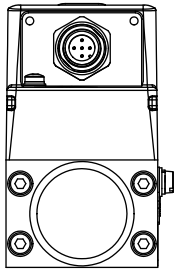

M12 plug, 5 pin (A-coded)	Pin	Configuration
	1	Shield
	2	24 V
	3	DGND
	4	CAN_H
	5	CAN_L

### 5.2. Analogue

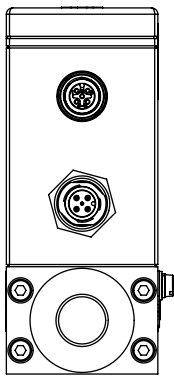

M12 socket, 5 pin (A-coded)	Pin	Configuration
	1	Digital input GND
	2	Digital input +
	3	Relay, Reference contact
	4	Relay, Opener (disconnect contact / normally closed (NC))
	5	Relay, Closer (make contact / normally open (NO))

M12 plug, 5 pin (A-coded)	Pin	Configuration
	1	Set value input GND (not connected for MFM)
	2	24 V
	3	GND
	4	Set value input (not connected for MFM)
	5	Analogue output for the measured value

### 5.3. PROFIBUS-DP

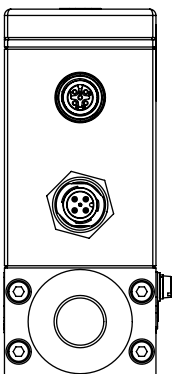

M12 socket, 5 pin (B-coded)	Pin	Configuration
	1	5 V
	2	RxD / TxD (Line A)
	3	DGND
	4	RxD / TxD (Line B)
	5	Not connected

M12 plug, 5 pin (A-coded)	Pin	Configuration
	1	Shield
	2	24 V
	3	GND
	4	Not connected
	5	Not connected

## 6. Performance specifications

### 6.1. Pressure Loss Diagram of the MFM

The diagram shows an example of the pressure loss characteristics when air flows through. To determine the pressure loss of another gas, the corresponding air equivalent must first be calculated and the basic fluidics used for the other gas taken into account.

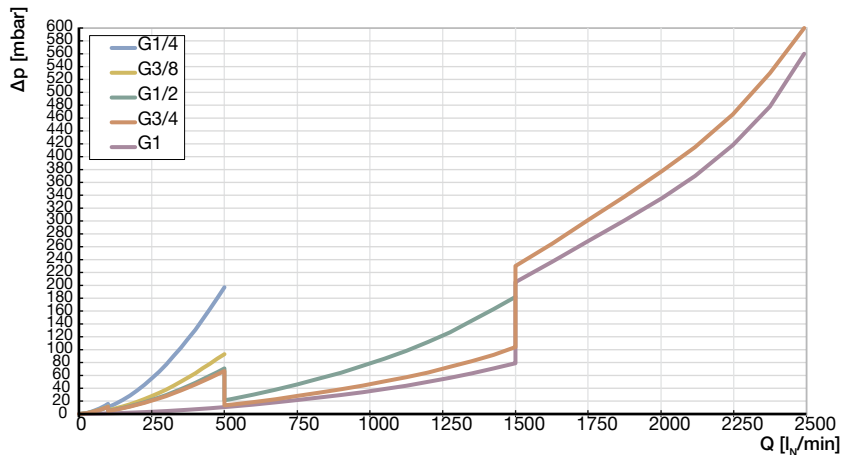

### 6.2. Flow characteristic

#### Nominal flow range of typical gases

**Note:**

- All values refer to 1.013 bara and 0 °C (Index N)
- Other gases and gas mixtures on request

Gas	Min. Q <sub>Nom</sub> [l <sub>N</sub> /min]	Max. Q <sub>Nom</sub> [l <sub>N</sub> /min]
Acetylene	20	320 (from 65 l <sub>N</sub> /min with air calibration)
Ammonia	8	1000
Argon	20	1600
Carbon dioxide	20	1000
Air, oxygen, nitrogen	20	2500
Methane	20	750
Propane	20	200

### 6.3. Derating diagram

#### Electromotive versions

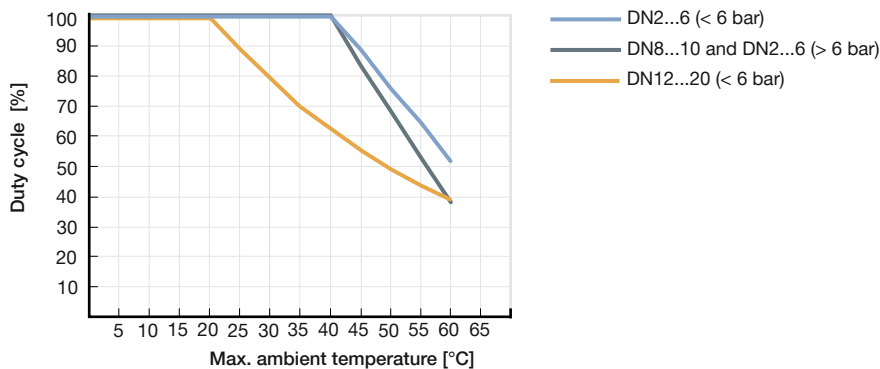

## 7. Product operation

### 7.1. Measuring principle

This sensor works as a hot-film anemometer in the so called CTA operational mode (Constant Temperature Anemometer). To do this, two resistors with precisely specified temperature coefficients located directly in the media flow and three resistors located outside the flow are connected together to form a bridge.

The first resistor in the gas flow ( $R_f$ ) measures the fluid temperature, while the second, low value resistor ( $R_s$ ) is heated so that it is maintained at a fixed, predefined overtemperature with respect to the fluid temperature. The heating current required to maintain this is a measure of the heat being removed by the flowing gas, and represents the primary measurement.

An adequate flow conditioning within the MFC and the calibration with high quality flow standards ensure that the mass of gas flowing per time unit can be derived from the primary signal with high accuracy.

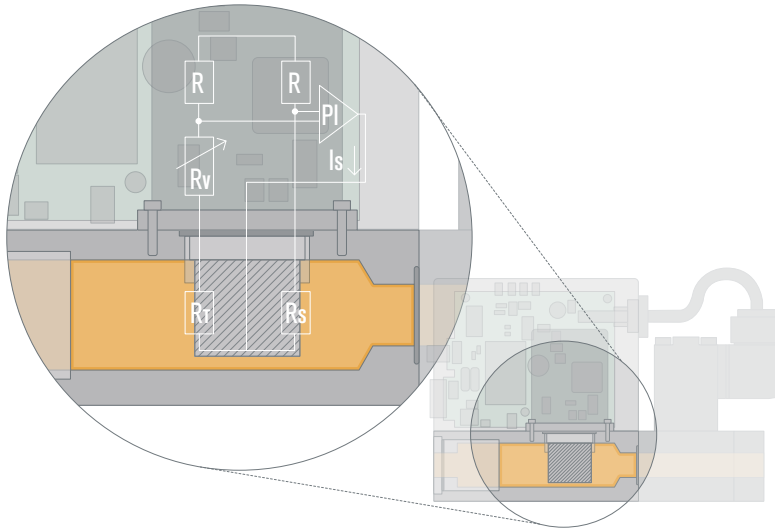

## 8. Product design and assembly

### 8.1. Product features

#### Measures to comply with ATEX requirements

**Note:**

Devices with ATEX conformity meet protection class IP65.

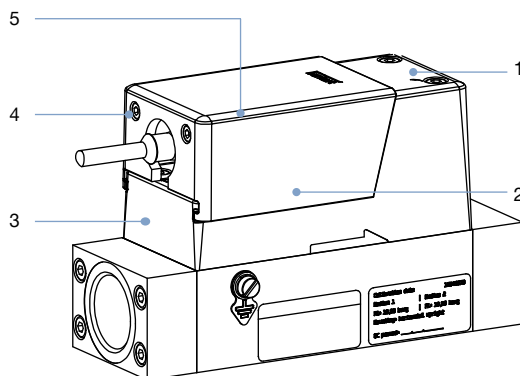

No.	Description
1	Standard requirements for cable glands are fulfilled for versions with external valve.
2	M12 plug achieves protection class IP65 with and without mounted counterpart.
3	Die-cast housing receives IP protection under high mechanical stress.
4	Screws prevent uncoupling of the M12 connection under tension.
5	Impact protection cap prevents damage of the M12 plug and all connected elements if mechanical stress is applied. No particular ATEX sockets are required.

## 9. Product accessories

### 9.1. Bürkert Communicator Software

**Note:**

To install the software, click [here](#) ►.

Part of Bürkert's EDIP program (Efficient Device Integration Platform) is the Bürkert Communicator. This software can be run under MS-Windows and it is available on Bürkert's website for free. The Bürkert Communicator allows convenient system configuration and parametrisation of all connected field devices. An accessory part, the bÜS stick serves as the interface between computer and process instruments (see "10.4. Ordering chart accessories" on page 21). It transfers "USB data" to "CAN data". The Communicator allows:

- Diagnosis
- Parametrization
- Registration and storage of process data
- To watch graph of process
- To update firmware of the device connected
- Guided re-calibration

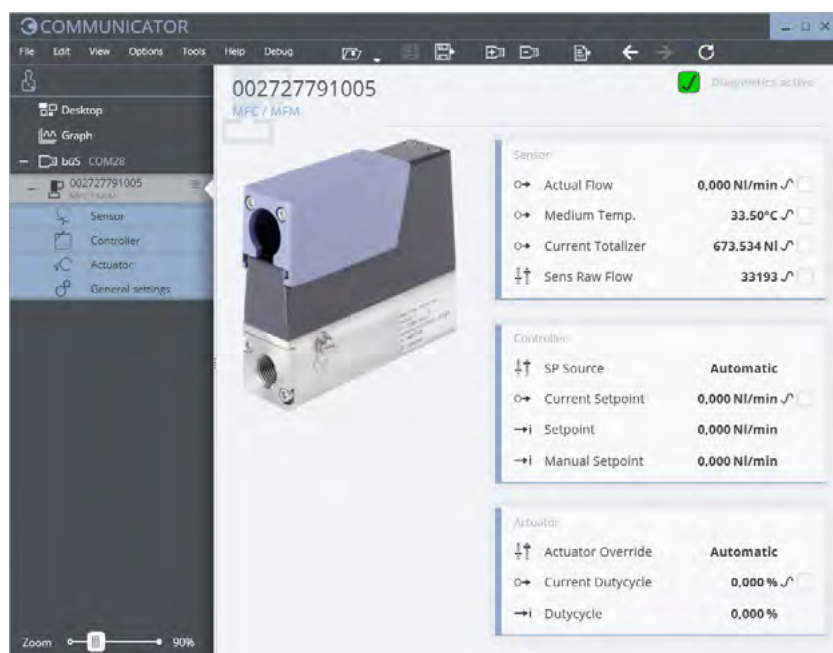

#### Type 8746 connection with Bürkert Communicator software

The interface to the "Bürkert Communicator" software tool is based on CANopen. The appropriate bus termination is mandatory. Hence, please activate, for Type 8746 with analogue or PROFIBUS interface, the termination resistor switch on the bÜS-stick. For Type 8746 bÜS / CANopen, this termination resistor should not be activated, in case the device is already integrated in a properly terminated bus network

To connect the MFC / MFM with the "Bürkert Communicator" software tool, you need a bÜS-stick. The bÜS-stick sets contain the necessary accessories.

- For Type 8746 bÜS / CANopen, the connection is made directly via the 5 pin M12 plug (bÜS-stick Set 1 contains the necessary accessories).
- For Type 8746, with analogue or PROFIBUS, the connection is made via the micro-USB socket on the device (bÜS-stick Set 2 contains the necessary accessories).

**ATTENTION:** No external power supply may be connected to the micro-USB socket! The power supply to the unit must be provided as described in chapter "5. Device/Process connections" on page 17.

## 10. Ordering information

### 10.1. Bürkert eShop – Easy ordering and quick delivery



**Bürkert eShop – Easy ordering and fast delivery**

You want to find your desired Bürkert product or spare part quickly and order directly? Our online shop is available for you 24/7. Sign up and enjoy all the benefits.

[Order online now](#)

### 10.2. Recommendation regarding product selection

**Note:**

The **product questionnaire form** at the end of this document contains the relevant fluid specification. Using the experience of Bürkert engineers already in the design phase provide us with a copy of the request containing the necessary data together with your inquiry or order.

For the proper choice of the actuator orifice within the MFC, not only the required maximum flow rate  $Q_{Nom}$ , but also the pressure values directly before and after the MFC ( $p_1$ ,  $p_2$ ) at this flow rate  $Q_{Nom}$  should be known. In general, these pressures are not the same as the overall inlet and outlet pressures of the whole plant, because usually there are additional flow resistors (tubing, additional shut-off valves, nozzles etc.) present both before and after the controller.

Please use the **product questionnaire form** at the end of this document to indicate the pressures directly before and after the MFC. If these are unknown or not accessible to a measurement, estimates are to be made by taking into account the approximate pressure drops over the flow resistors before and after the MFC, respectively, at a flow rate of  $Q_{Nom}$ . In addition, please quote the maximum inlet pressure  $p_1$  max. to be encountered. This data is needed to make sure the actuator is able to provide a close-tight function within all the specified modes of operation.

### 10.3. Bürkert product filter

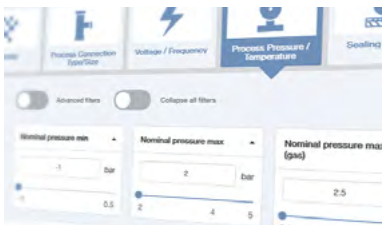

**Bürkert product filter – Get quickly to the right product**





You want to select products comfortably based on your technical requirements? Use the Bürkert product filter and find suitable articles for your application quickly and easily.





















[Try out our product filter](#)

### 10.4. Ordering chart accessories

**Note:**

- A büS-Stick is required to connect the MFC / MFM with the “Bürkert Communicator” software tool. It is connected via the micro USB-socket on the device (büS-Stick set 2 contains the necessary accessories).
- Please note: The interface to our software tool “Bürkert Communicator” is based on CANopen. A corresponding bus termination is mandatory. Therefore please activate the switchable terminating resistor on the büS-Stick.

Description	Article no.
<b>General accessories</b>	
Power supply Type 1573 for rail mounting, 100...240 V AC / 24 V DC, 1.25 A, NEC Class 2 (UL 1310)	772438 
Power supply Type 1573 for rail mounting, 100...240 V AC / 24 V DC, 1 A, NEC Class 2 (UL 1310)	772361 
Power supply Type 1573 for rail mounting, 100...240 V AC / 24 V DC, 2 A, NEC Class 2 (UL 1310)	772362 
Power supply Type 1573 for rail mounting, 100...240 V AC / 24 V DC, 4 A	772363 

Description	Article no.
büS-Stick Set 1 incl. cable (M12 and Micro-USB) Stick with integrated terminating resistor, power supply and software	772426 
büS-Stick Set 2 incl. cable (M12 and Micro-USB) Stick with integrated terminating resistor	772551 
Configuration memory (Industrial µSim-Card)	On request
Software Bürkert Communicator	Download from <a href="http://www.burkert.com">www.burkert.com</a>
<b>CANopen/büS</b>	
büS cable extension M12, 0.1 m	772492 
büS cable extension M12, 0.2 m	772402 
büS cable extension M12, 0.5 m	772403 
büS cable extension M12, 1 m	772404 
büS cable extension M12, 3 m	772405 
Connector M12, socket, straight <sup>1.)</sup>	772416 
Connector M12, plug, straight <sup>1.)</sup>	772417 
Connector M12, socket, angled <sup>1.)</sup>	772418 
Connector M12, plug, angled <sup>1.)</sup>	772419 
<b>CANopen/büS</b>	
Y-junction	772420 
Y-junction for connecting two separately powered segments of a büS network	772421 
Termination resistor 120 Ohm M12 plug	772424 
Termination resistor 120 Ohm M12 socket	772425 
LabVIEW device driver	On request
EDS-File (CANopen)	Download from <a href="http://www.burkert.com">www.burkert.com</a>
<b>Analogue</b>	
Connection cable M12 plug (A-coded) on open leads, 5 m	566923 
Connection cable M12 plug (A-coded) on open leads, 10 m	571393 
Connection cable M12, socket (A-coded) on open leads, 5 m	560365 
Connection cable M12, socket (A-coded) on open leads, 10 m	563108 
<b>PROFIBUS-DP</b>	
Connection cable M12, socket (A-coded) on open leads, 5 m	560365 
Connection cable M12, socket (A-coded) on open leads, 10 m	563108 
GSD-File (PROFIBUS-DP)	Download from <a href="http://www.burkert.com">www.burkert.com</a>

1.) It is possible that the M12 connectors cannot be used together on the same side of a Y-junction. If that is the case, please use a prefabricated cable which uses typically a thinner connector.

# Bürkert – Close to You

For up-to-date addresses  
please visit us at  
[www.burkert.com](http://www.burkert.com)

DTS 1000241027 EN Version: Q.Status: RL (released | freigegeben | valide) printed: 06.08.2021



## Product Enquiry Form - Mass Flow Controller For Gases

Thank you for your interest in our products! In order to provide you with optimum advice, please fill out the following form and send it to your **Bürkert representative** or e-mail address: [info@burkert.com](mailto:info@burkert.com). All information submitted will of course be kept strictly confidential.

Please fill in the **required fields!**  \*

\*Note: The interactive functions of this PDF may be restricted depending on the PDF reader used.

Personal Information			
Company		Contact person	
Customer no.		Department	
Street		Postcode / Town	
Telephone no.		Email	

Delivery			
MFC Application	MFM Application	Quantity	Required delivery date

Medium data			
Type of gas or gas mixture			
Medium temperature		°C /	°F
Ambient temperature		°C /	°F

Fluidic data					
Flow range $Q_{Nom}$		Min.		Max.	unit Ref. N <sup>1.)</sup> Ref. S <sup>1.)</sup>
Inlet pressure at $Q_{Nom}$ <sup>2.)</sup>	$p_1$	=		barg <sup>3.)</sup>	
Outlet pressure at $Q_{Nom}$	$p_2$	=		barg <sup>3.)</sup>	
Max. inlet pressure	$p_{1max}$	=		barg <sup>3.)</sup>	
Port connection	<b>Compression fitting</b>		<b>Subbase</b>	<b>Vacuum fitting</b>	
	<b>Thread:</b>		G (DIN ISO 228/1)	NPT (ANSI B1.2)	
			1/4"    3/8"	1/2"    3/4"	1"
Installation	horizontal, valve upright			vertical, upward flow	
	horizontal, valve horizontal			vertical, downward flow <sup>4.)</sup>	

1.) Reference conditions: Ref. N: T=0°C, P=1,013 bar(a); Ref. S: T=20°C, P=1,013 bar(a)

2.) Corresponds to the calibration pressure

3.) Please indicate all pressure values as overpressure to atmospheric pressure [barg] (g = relative pressure)

4.) Possible reduction of the setting range to 1:10 for a vertical downwards flow

Material specifications		
Body	Aluminium	Stainless steel
Seals	FKM	EPDM

Electrical data				
IP protection	Yes (IP65)		No (IP20 or better)	
Control / Communication <b>Note:</b> Please choose <b>one</b> of the following options!	<b>Normsignal</b>	<b>CANopen/büS</b>	<b>PROFIBUS DP</b>	<b>Industrial Ethernet</b>
	0 ... 5 V	CANopen		PROFINET
	0 ... 10 V	büS		Ethernet IP
	0 ... 20 mA			Modbus TCP
Connection <b>Note:</b> Please choose <b>one</b> of the following options!	4 ... 20 mA			EtherCAT
	D Sub socket	M12 socket	D Sub socket	(RJ45 always standard)
	Terminal block	Terminal block	M12 socket	



<b>Approvals / Conformities</b>
UL
ATEX II Cat. 3 G/D, IECEx
USP Class VI conformity
FDA conformity
EG 1935/2004 conformity

<b>Additional Requirements / Comment</b>

DTS 1000241027 EN Version: Q Status: RL (released | freigegeben | validé) printed: 06.08.2021