



## Level measurement device with guided radar - sanitary version

- Universal level measurement device for liquids
- Liquid interface measurement
- Insensitive to dust and steam
- 4... 20 mA/Hart, 2 wires
- ATEX/IECEX certifications

Product variants described in the data sheet may differ from the product presentation and description.

### Can be combined with

	<b>Type 8619</b> ▶ multiCELL - Multi-channel and multi-function transmitter/controller
	<b>Type 8611</b> ▶ eCONTROL - Universal controller
	<b>Type 8802</b> ▶ ELEMENT continuous control valve systems - overview
	<b>Type 8644</b> ▶ Remote Process Actuation Control System AirLINE
	<b>Type 8793</b> ▶ Digital electropneumatic Process Controller SideControl

### Type description

The Type 8189 is a level measurement device with interchangeable rod probe, designed for continuous level measurement.

The unit is suitable for liquids, for industrial use in all areas of process technology. But the main application targets are in Food and Beverage (F&B) and pharmaceutical tanks to the new rod in stainless steel 1.4435 with Ra < 0.76 µm. For applications with corrosive liquids a PFA coated version is available.

Even process conditions such as strong steam generation, density fluctuations or changes of the dielectric constant do not influence the accuracy of the measurement. Build-up or condensation on the probe or vessel wall does not influence the measurement result.

## Table of contents

<b>1. General technical data</b>	<b>3</b>
<hr/>	
<b>2. Approvals</b>	<b>5</b>
2.1. Certifications.....	5
2.2. Certificates.....	5
<hr/>	
<b>3. Materials</b>	<b>5</b>
3.1. Chemical Resistance Chart – Bürkert resistApp.....	5
<hr/>	
<b>4. Dimensions</b>	<b>6</b>
4.1. With clamp process connection.....	6
4.2. With process connection according to DIN 11851.....	7
<hr/>	
<b>5. Performance specifications</b>	<b>8</b>
5.1. Measuring range and blocking distance diagram.....	8
5.2. Measurement deviation diagram.....	8
Rod probe version in water.....	8
Rod probe version in oil.....	9
5.3. Temperature derating diagram.....	9
<hr/>	
<b>6. Product operation</b>	<b>9</b>
6.1. Measuring principle.....	9
6.2. Product operation notes.....	9
Set up with display/configuration module.....	10
Set up with PACTware™/DTM and HART communication.....	10
<hr/>	
<b>7. Ordering information</b>	<b>10</b>
7.1. Bürkert eShop – Easy ordering and quick delivery.....	10
7.2. Bürkert product filter.....	11
7.3. Ordering chart.....	11
7.4. Ordering chart accessories.....	11

## 1. General technical data

### Product properties

#### Materials

Please make sure the device materials are compatible with the fluid you are using. Detailed information can be found in chapter [“3.1. Chemical Resistance Chart – Bürkert resistApp” on page 5.](#)

#### Non wetted parts

Housing	Plastic PBT (Polyester) and stainless steel 316L (1.4404)
Cover	PC transparent
Seal between housing and cover	EPDM
Cable gland	PA
Blind plug	PA
Ground terminal	Stainless steel 316L

#### Wetted parts

Process connection	Stainless steel 316L (1.4404 or 1.4435) and PEEK
Process seal	EPDM
Rod-Ø 8 mm	Stainless steel 316L (1.4435), polished
Dimensions	Detailed information can be found in chapter <a href="#">“4. Dimensions” on page 6.</a>
Weights	<ul style="list-style-type: none"> <li>• Housing: 890 g</li> <li>• Rod-Ø 8 mm: approx. 400 g/m</li> </ul>
Surface quality	Rod: $Ra \leq 0.76 \mu\text{m}$ (with low delta ferrite content)
Probe length	0.3...4 m (lateral load: 10 Nm)
Measured variable	Level of liquids
Measuring range	0.08...4 m Detailed information can be found in chapter <a href="#">“5.1. Measuring range and blocking distance diagram” on page 8.</a>
Blocking distance	<ul style="list-style-type: none"> <li>• In water: <ul style="list-style-type: none"> <li>– from top of probe: 80 mm</li> <li>– from bottom of probe: 0 mm</li> </ul> </li> <li>• In oil <ul style="list-style-type: none"> <li>– from top of probe: 150 mm</li> <li>– from bottom of probe: 100 mm</li> </ul> </li> </ul>
Damping (63 % of the input variable)	0...999 s, adjustable
Step response time <sup>1.)</sup>	$\leq 3$ s

#### Product accessories

Display	LCD in full dot matrix. Detailed information can be found in chapter <a href="#">“7.4. Ordering chart accessories” on page 11.</a>
---------	--

### Performance data

Measurement deviation <sup>2,3.)</sup>	According to DIN EN 60770-1: $\pm 2$ mm Detailed information can be found in chapter <a href="#">“5.2. Measurement deviation diagram” on page 8.</a>
Measuring range resolution	<1 mm
Measuring cycle time	<500 ms
Temperature drift	<ul style="list-style-type: none"> <li>• Digital output: <math>\pm 3</math> mm/10 K, max. 10 mm</li> <li>• Current output: &lt;0.03 %/10K relating to the 16 mA span or <math>\leq 0.3</math> %</li> </ul>
Max. filling/emptying speed	1 m/min (products with high dielectric constant (>10) up to 5 m/min.)
Non-repeatability	$\leq \pm 1$ mm
Vibration resistance	1 g with 5...200 Hz according to EN 60068-2-6 (vibration at resonance) with rod length 50 cm
Shock resistance	25 g, 6 ms according to EN 60068-2-27 (mechanical shock) with rod length 50 cm

### Electrical data

Operating voltage ( $U_n$ )	<ul style="list-style-type: none"> <li>• Without display/configuration module: <ul style="list-style-type: none"> <li>– 9.6...35 V DC</li> <li>– 9.6...30 V DC (Ex ia instrument)</li> </ul> </li> <li>• With display/configuration module: <ul style="list-style-type: none"> <li>– 16...35 V DC</li> <li>– 16...30 V DC (Ex ia instrument)</li> </ul> </li> </ul>
-----------------------------	---

Power source (not supplied)	Limited power source according to UL/EN 60950-1 standards or limited energy circuit according to UL/EN 61010-1 §9.4
Starting current	≤3.6 mA, ≤10 mA for 5 ms after the switching on
DC reverse polarity protection	Yes
Output signal	4...20 mA/HART
Signal resolution	0.3 µA
Range of the output signal	3.8...20.5 mA/HART (default setting)
Load resistor	$(U_n - U_{min,n})/0.022 \text{ A}$
Fault signal	Current output: last valid measured value, ≥21 mA or <3.6 mA (adjustable)
Max. output current	21.5 mA
Residual ripple (for DC)	<ul style="list-style-type: none"> <li>For <math>9.6 \text{ V} &lt; U_n &lt; 18 \text{ V}</math>: ≤0.7 V<sub>eff</sub> (16...400 Hz)</li> <li>For <math>18 \text{ V} &lt; U_n &lt; 35 \text{ V}</math>: ≤1.0 V<sub>eff</sub> (16...400 Hz)</li> </ul>
Voltage supply cable	<ul style="list-style-type: none"> <li>Cable diameter: 5...9 mm</li> <li>Wire cross-section (spring-loaded terminals): <ul style="list-style-type: none"> <li>Massive wire, stranded wire: 0.2...2.5 mm<sup>2</sup> (AWG 24...14)</li> <li>Stranded wire with end sleeve: 0.2...1.5 mm<sup>2</sup> (AWG 24...16)</li> </ul> </li> </ul>

**Medium data**

Process temperature	-20...+130 °C (-4...+266 °F) (for sterilisation process: up to +150 °C (+302 °F) for max. 120 min)
Process pressure	Vessel pressure: -1...16 bar (-14.51...232.16 PSI/-100...1600 kPa)
Dielectric constant (min.)	$\epsilon_r > 1.6$

**Product connections**

Process connection	<ul style="list-style-type: none"> <li>Clamp 2"</li> <li>DIN 11851 DN 50</li> </ul>
Electrical connections	Cable gland M20x1.5

**Approvals and Certificates****Standards**

Degree of protection according to IEC/EN 60529	IP66/IP67 with cable plug mounted and tightened M20x1.5
Overvoltage category according to IEC 61010-1	Category III
Protection class according to IEC 61010-1	Class III

**Directives**

CE directives	The applied standards, which verify conformity with the EU Directives, can be found on the EU Type Examination Certificate and/or the EU Declaration of conformity (if applicable)
NAMUR recommendations	<ul style="list-style-type: none"> <li>NE21 – Electromagnetic compatibility of equipment</li> <li>NE43 – Signal level for fault information from measuring transducers</li> <li>NE53 – Compatibility of field devices and display/adjustment components</li> <li>NE107 – Self-monitoring and diagnosis of field devices</li> </ul>
Certificate	FDA declaration of conformity. Detailed information can be found in chapter <b>"2.2. Certificates"</b> on page 5.

**Certifications**

IECex / ATEX	IEC/EN60079-0, IEC/EN60079-11, IEC/EN60079-26. Detailed information can be found in chapter <b>"2.1. Certifications"</b> on page 5.
--------------	---

**Environment and installation**

Ambient temperature	Operation and storage: -40...+80 °C (-40...+176 °F) (with display/configuration module)
Temperature derating	Detailed information can be found in chapter <b>"5.3. Temperature derating diagram"</b> on page 9.
Relative air humidity	<ul style="list-style-type: none"> <li>Operation: max. 75 %, without condensation</li> <li>Storage: 20...85 %, without condensation</li> </ul>
Height above sea level	Max. 2000 m (by default; max. 5000 m with connected overvoltage protection)
Pollution degree	Degree 4 (when used with fulfilled housing protection)

1.) Time span, after a sudden change in the measuring distance of max. 0.5 m in liquid applications, until the output signal has assumed for the first time 90 % of the final value (IEC 61298-2).

2.) Depending on the mounting conditions, deviations can occur which can be rectified by adapting the adjustment or changing the measured value offset in the DTM service mode.



3.) The blocking distances can be optimized by a false signal suppression.

## 2. Approvals

### 2.1. Certifications

**Note:**

Devices with Ex or IEC certification have different technical data.

Certificate	Description	
	<b>TÜV 14 ATEX 7490 X</b> <b>Specifications Ex</b> Ex Protection                      Categorie 1G, ½G or 2G Ex Certification                    EEx ia IIC T6 <b>Conformity specifications</b> Operating voltage Ui              30 V Short circuit rating Ii             131 mA Power limitation Pi                983 mW Ambient temperature            -50...+46 °C (-58...+114.8 °F) (depending on the categorie) Internal capacity Ci               Negligible Internal inductivity Li            ≤5 µH	
		<b>IECEX TUR 14.0014 X</b> <b>Specifications Ex</b> Ex Protection                      Categorie 1G, ½G or 2G Ex Certification                    EEx ia IIC T6 <b>Conformity specifications</b> Operating voltage Ui              30 V Short circuit rating Ii             131 mAs Power limitation Pi                983 mW Ambient temperature            -50...+46 °C (-58...+114.8 °F) (depending on the categorie) Internal capacity Ci               Negligible Internal inductivity Li            ≤5 µH

### 2.2. Certificates

Certificate	Description
FDA	<b>FDA</b> The devices comply in their composition with the Code of Federal Regulations published by the FDA (Food and Drug Administration, USA).

## 3. Materials

### 3.1. Chemical Resistance Chart – Bürkert resistApp

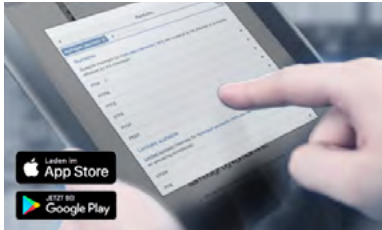

**Bürkert resistApp – Chemical Resistance Chart**

You want to ensure the reliability and durability of the materials in your individual application case? Verify your combination of media and materials on our website or in our resistApp.

[Start Chemical Resistance Check](#)

## 4. Dimensions

### 4.1. With clamp process connection

**Note:**

Dimensions in mm (unless specified differently)

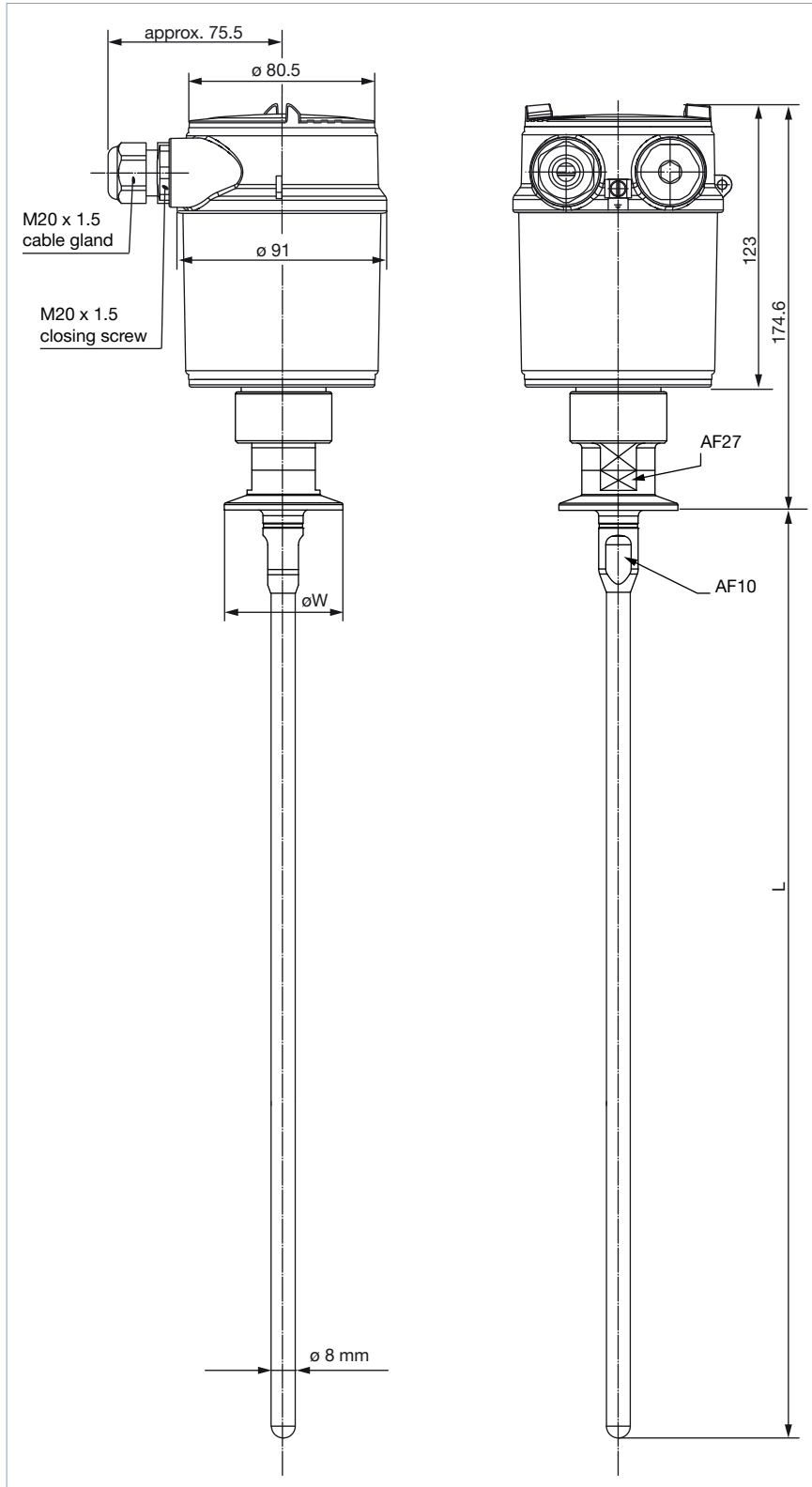

Clamp connection	Ø W	L
1", 1½"	50.5	0.3...4 m
2"	64.0	
2½"	77.5	
3"	91.0	

4.2. With process connection according to DIN 11851

Note:

Dimensions in mm (unless specified differently)

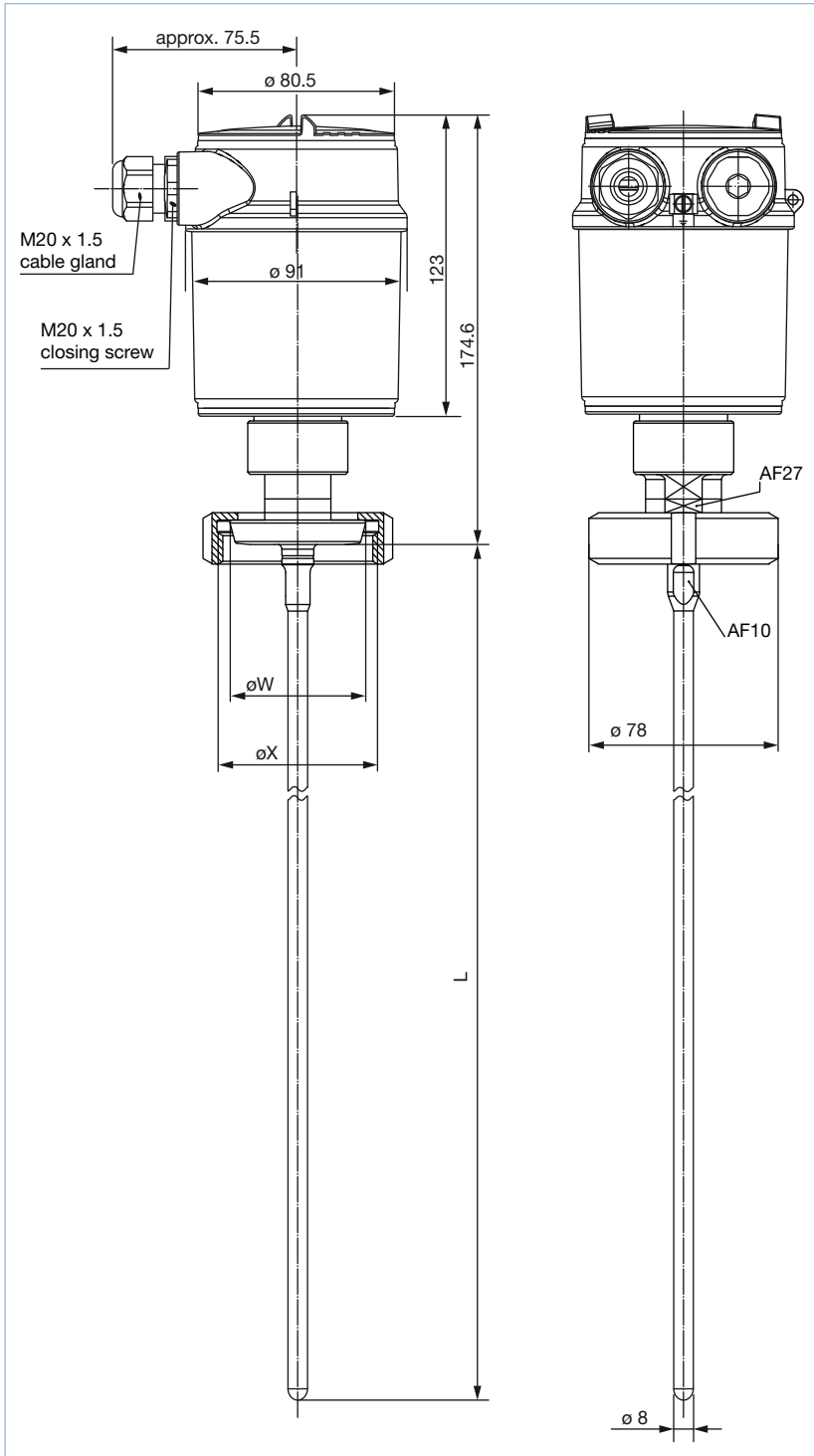

DIN 11851 connection	Ø W	Ø X	L
DN 32	50.0	Rd 58 × 1/6	0.3...4 m
DN 40	56.0	Rd 65 × 1/6	
DN 50	68.5	Rd 78 × 1/6	
DN 65	86.0	Rd 58 × 1/6	

## 5. Performance specifications

### 5.1. Measuring range and blocking distance diagram

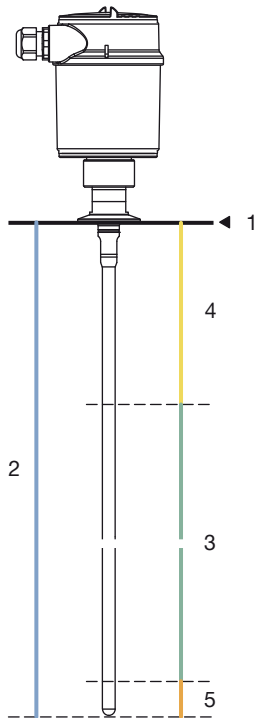

No.	Description	
1	Reference plane	-
2	Measuring probe length	0.3...4 m
3	Measurement range	In water: 0.08...4 m In oil: 0.15...3.95 m
4	Upper block distance	In water: 0.08 m In oil: 0.15 m
5	Lower block distance	In water: 0 m In oil: 0.1 m

### 5.2. Measurement deviation diagram

#### Rod probe version in water

**Note:**

The blocking distance is indicated by the grey area in the diagram. No measurement is possible in this area.

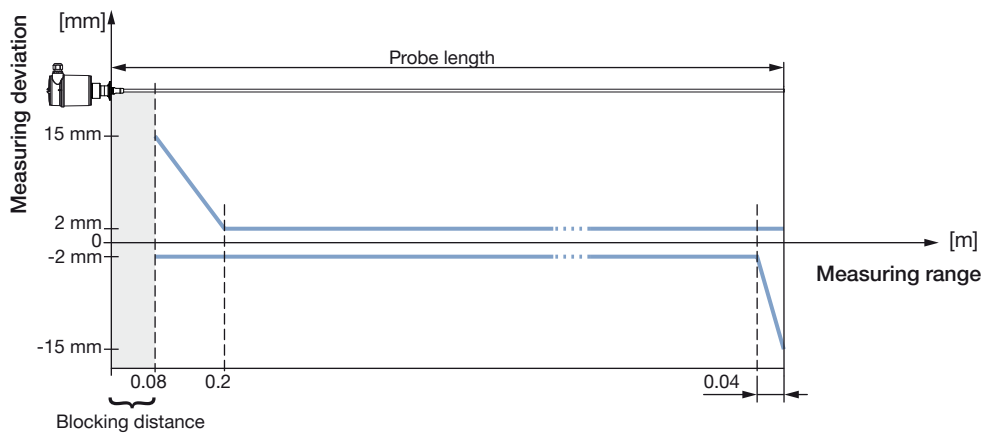



### Rod probe version in oil

#### Note:

The blocking distance is indicated by the grey area in the diagram. No measurement is possible in this area.

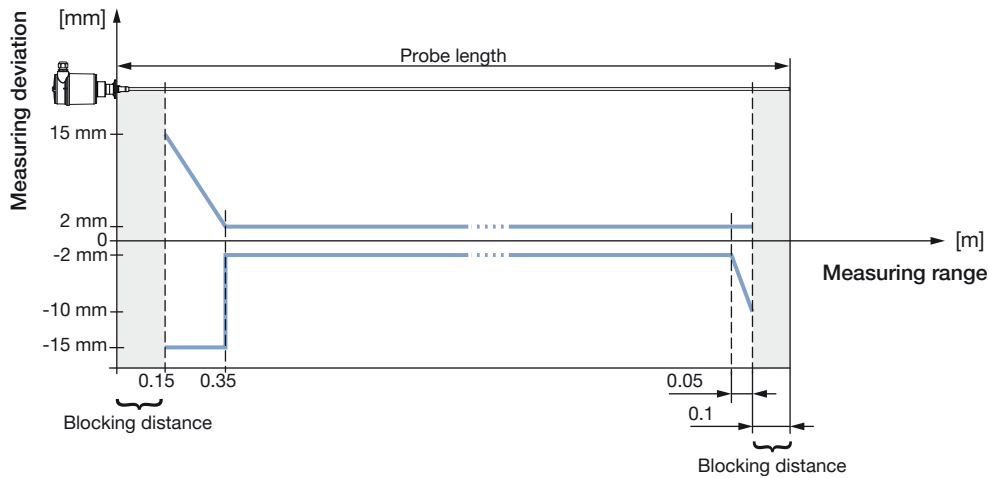

### 5.3. Temperature derating diagram

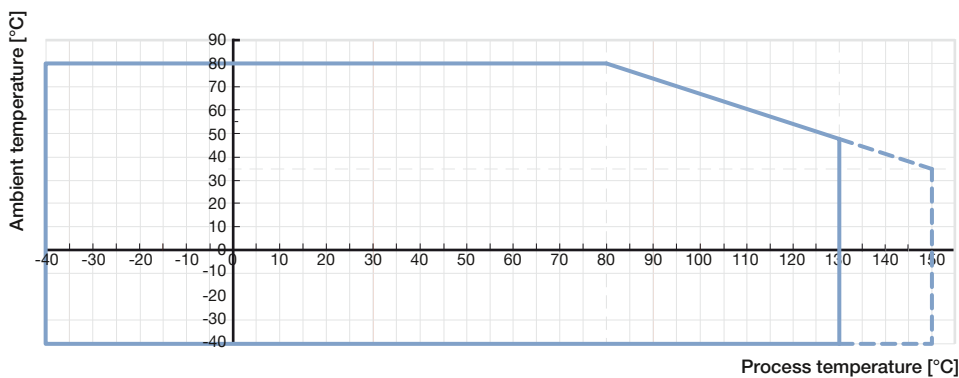

## 6. Product operation

### 6.1. Measuring principle

High frequency microwave pulses are guided along a rod. When they reach the product surface, the microwave pulses are reflected and received by the processing electronics. The running time is evaluated by the instrument and outputted as distance. Time consuming adjustment with medium is not necessary. The instruments are pre-set to the ordered probe length. The shortenable rod version can be adapted individually to the local requirements.

### 6.2. Product operation notes

#### Note:

The measuring device can be adjusted with:

- The display/configuration module
- The suitable Bürkert DTM in conjunction with a software according to the FDT/DTM standard, e.g. PACTware™ and PC
- With a HART handheld

The entered parameters are generally saved in the measuring device Type 8189. Optionally, parameters may also be uploaded and downloaded with the display/configuration module or saved in a file by using PACTware™/8189-DTM.

Set up with display/configuration module

Display/configuration module	Description
	<p>The display/configuration module can be inserted into the measuring device and removed again at any time. It is not necessary to interrupt the power supply. The measuring device is adjusted via the four keys of the display/configuration module.</p>

Set up with PACTware™/DTM and HART communication

Assembly	Description								
	<p>The measuring device can be operated thanks to PACTware™, via HART communication. An interface adapter is necessary for the adjustment with PACTware™. For the setup of the Type 8189, the DTM in the actual version must be used. The basic version of DTM incl. PACTware™ is available as a free-of-charge download from the internet at <a href="http://www.burkert.com">www.burkert.com</a> ▶.</p> <p><b>Connecting the PC via HART</b></p> <table border="1"> <thead> <tr> <th>No.</th> <th>Description</th> </tr> </thead> <tbody> <tr> <td>1</td> <td>Measuring device Type 8189</td> </tr> <tr> <td>2</td> <td>HART-USB Modem</td> </tr> <tr> <td>3</td> <td>Resistance 250 Ω</td> </tr> </tbody> </table> <p>Necessary components:</p> <ul style="list-style-type: none"> <li>• Measuring device Type 8189</li> <li>• PC with PACTware™ and suitable Bürkert DTM</li> <li>• HART-USB Modem</li> <li>• Resistance approx. 250 Ω</li> <li>• Power supply unit</li> </ul>	No.	Description	1	Measuring device Type 8189	2	HART-USB Modem	3	Resistance 250 Ω
No.	Description								
1	Measuring device Type 8189								
2	HART-USB Modem								
3	Resistance 250 Ω								

7. Ordering information

7.1. Bürkert eShop – Easy ordering and quick delivery



**Bürkert eShop – Easy ordering and fast delivery**

You want to find your desired Bürkert product or spare part quickly and order directly? Our online shop is available for you 24/7. Sign up and enjoy all the benefits.

Order online now

DTS 1000244852 EN Version: D Status: RL (released | freigegeben | validé) printed: 27.11.2020

## 7.2. Bürkert product filter



### Bürkert product filter – Get quickly to the right product

You want to select products comfortably based on your technical requirements? Use the Bürkert product filter and find suitable articles for your application quickly and easily.

[Try out our product filter](#)

## 7.3. Ordering chart

### Note:

All following versions are supplied with display/configuration module.

Description	Operating voltage	Output	Probe	Length	Electrical connection	Article no.
<b>Standard version</b>						
Clamp 2"	9.6...35 V DC	4...20 mA/HART (2 wires)	Rod	1 m	Cable gland M20 × 1.5	565850
DIN 11851, DN 50				2 m		565852
				1 m		565851
				2 m		565853
<b>Ex version - ATEX certification</b>						
Clamp 2"	9.6...30 V DC	4...20 mA/HART (2 wires)	Rod	1 m	Cable gland M20 × 1.5	565854
DIN 11851, DN 50				2 m		565856
				1 m		565855
				2 m		565857
<b>Ex version - IECex certification</b>						
Clamp 2"	9.6...30 V DC	4...20 mA/HART (2 wires)	Rod	1 m	Cable gland M20 × 1.5	565858
DIN 11851, DN 50				2 m		565860
				1 m		565859
				2 m		565861

Further versions on request	
<b>Material</b> FFKM	<b>Temperature</b> -20...+150 °C
<b>Process connection</b> <ul style="list-style-type: none"> <li>Clamp 1½", 2½", 3"</li> <li>DIN 11851 DN 32, DN 40, DN 65</li> </ul>	<b>Additional</b> Without display/configuration module

## 7.4. Ordering chart accessories

Description	Article no.
Set with 2 reductions M20 × 1.5/NPT ½" + 2 neoprene flat seals for cable gland + 2 screw-plugs M20 × 1.5	551782
Hart-USB Modem	560177
Set with a display/configuration module, a transparent cover and a seal ring	559279
Set with a transparent cover and a seal ring	561006

# Bürkert – Close to You

For up-to-date addresses  
please visit us at  
[www.burkert.com](http://www.burkert.com)

DTS 1000244852 EN Version: D Status: RL (released | freigegeben | validé) printed: 27.11.2020

